

---

# Quality Assurance Project Plan For Monitoring Stormwater Retrofit in the Echo Lake Drainage Basin – RSMP Effectiveness Study

---

June 2015



**King County**

Department of Natural Resources and Parks  
Water and Land Resources Division

**Science and Technical Support Section**

King Street Center, KSC-NR-0600  
201 South Jackson Street, Suite 600  
Seattle, WA 98104

206-477-4800 TTY Relay: 711

[www.kingcounty.gov/EnvironmentalScience](http://www.kingcounty.gov/EnvironmentalScience)

Alternate Formats Available



# Quality Assurance Project Plan For Monitoring Stormwater Retrofit in the Echo Lake Drainage Basin – RSMP Effectiveness Study

## Prepared for:

Washington State Department of Ecology  
Washington Stormwater Workgroup

## Submitted by:

Carly Greyell  
King County Water and Land Resources Division  
Department of Natural Resources and Parks

## Funded in part by:

Pooled Resources of the Regional Stormwater Monitoring Program



**King County**

Department of  
Natural Resources and Parks

**Water and Land Resources Division**





# Citation

---

King County. 2015. Quality Assurance Project Plan For Monitoring Stormwater Retrofit in the Echo Lake Drainage Basin – RSMP Effectiveness Study. Prepared by Carly Greyell, Water and Land Resources Division. Seattle, Washington.

# Table of Contents

---

Approvals .....	vi
1.0 Background .....	1
1.1 Study Area.....	1
1.1.1 Contaminants of Interest .....	2
1.1.2 Changes in Stormwater Infrastructure.....	7
1.2 Previous Stormwater Sampling Efforts.....	8
2.0 Project Description .....	10
2.1 Sampling Individual Treatment Features.....	10
2.2 System-wide Evaluation.....	11
2.2.1 Detention Tank System.....	11
2.2.2 Ongoing Echo Lake Monitoring.....	12
3.0 Organization and Schedule .....	13
4.0 Quality Objectives.....	16
4.1 Precision.....	16
4.2 Bias .....	16
4.3 Sensitivity.....	16
4.4 Accuracy .....	17
5.0 Sampling Design.....	18
5.1 Site Description.....	18
5.2 Qualifying Storm Event Criteria for Sampling .....	19
5.3 Measured Parameters .....	19
5.4 Representativeness.....	20
5.5 Comparability .....	21
5.6 Completeness .....	23
6.0 Sampling and Monitoring Procedures.....	24
6.1 Sample Collection Procedures – Individual Enhanced Treatment Features .....	24
6.1.1 Toxicity Tests Sample Collection .....	25
6.1.2 Summary of Sampling Strategy for Individual Enhanced Treatment Features .....	25
6.2 Sample Collection Procedures – Detention Tank System.....	26

6.2.1	Flow Meter Installation and Analysis.....	26
6.2.2	Flow-weighted Composite Sampling.....	27
6.3	Sampling Initiation.....	28
6.3.1	Monitoring Forecast.....	28
6.3.2	Sampling Initiation Procedures.....	29
6.4	Sampling Considerations.....	29
6.5	Additional Sampling Equipment.....	29
6.6	Sample Handling Procedures.....	30
6.6.1	Qualifying Samples – Post-Sampling.....	30
6.6.2	Sample Delivery and Storage.....	33
6.6.3	Chain of Custody.....	35
6.6.4	Sample Documentation.....	35
6.7	Decontamination Procedures.....	36
6.8	Collection of QA/QC Samples.....	36
6.9	Periodic Preventative Maintenance.....	37
6.10	Additional Resources or References to Assist with this Section.....	37
7.0	Measurement Procedures.....	38
7.1	KCEL Analytical Methods and Detection Limits.....	38
7.2	PCB Congener Analytical Methods and Detection Limits.....	39
7.3	Toxicity Test Procedures.....	42
8.0	Quality Control.....	44
8.1	Field Measurements.....	45
8.2	Conventionals and Nutrients.....	45
8.3	Microbiology.....	46
8.4	Metals.....	46
8.5	Organic Compounds - KCEL.....	46
8.6	PCB Congeners.....	48
8.7	Corrective Action for QC Problems.....	49
8.8	Toxicity Tests.....	50
8.8.1	<i>Daphnia pulex</i> Acute Toxicity Test.....	50
8.8.2	<i>Ceriodaphnia dubia</i> Chronic Toxicity Test.....	51
8.9	Flow Data.....	51

8.10	Audits.....	52
9.0	Data Management, Verification, and Reporting.....	53
9.1	Data Storage.....	53
9.2	Data Verification and Validation.....	53
9.2.1	Analytical Data.....	53
9.2.2	Flow Data.....	56
9.2.3	Rain Gauge Data.....	57
9.3	Data Reduction, Review, and Reporting.....	57
10.0	Data Quality Assessment and Data Analysis.....	59
11.0	References.....	61

## Figures

Figure 1.	Subbasin Drainage Areas in the Echo Lake Basin.....	3
Figure 2.	Current Stormwater Conveyance System in the Echo Lake Drainage Basin.....	5
Figure 3.	Sample Analysis Decision Tree Based On Paired Sample Volume.....	32

## Tables

Table 1.	Stormwater Treatment Technologies Added in the Echo Lake Drainage Basin.....	7
Table 2.	Summary of Stormwater Quality Across All Seven Subbasins Sampled within the Echo Lake Drainage Basin (2004). .....	8
Table 3.	Summary of Stormwater Quality at Echo Lake’s Southwest Stormwater Outfall (2010-2011).....	9
Table 4.	Team Member (and Outside Contract*) Contact Information.....	14
Table 5.	Schedule of Tasks.....	15
Table 6.	Sample Locations.....	18
Table 7.	Individual Enhanced Treatment or Flow Control Feature Description and Comparability.....	22
Table 8.	Historical Dataset Characteristics Compared to Proposed Sampling and Analysis for the Current Study.....	23
Table 9.	Sampling strategy for the individual enhanced treatment features.....	25
Table 10.	Sampling strategy for the DTS.....	28

Table 11.	Prioritized Parameter List with Sample Volume, Container, Preservation, Storage, and Holding Time Requirements .....	34
Table 12.	QA/QC Samples Required for Each Sampling Method Option.....	36
Table 13.	Method and Sensitivity for Parameters Analyzed in the Field .....	38
Table 14.	Method and Detection Limit Goals for Parameters Analyzed at the KCEL.....	39
Table 15.	Detection Limits for PCB Congeners.....	40
Table 16.	Field Measurement QC Measurements and Control Limits.....	45
Table 17.	Conventional and Nutrient QC Samples and Control Limits .....	45
Table 18.	Metals QC Samples and Control Limits.....	46
Table 19.	NWTPH-Dx QC Samples and Control Limits.....	47
Table 20.	Individual PAH Matrix Spike Recovery Limits.....	47
Table 21.	Individual PAH Spike Blank Recovery Limits .....	48
Table 22.	Laboratory QC Limits for PAH Surrogate Recoveries.....	48
Table 23.	Labeled Surrogates and Recovery Standards Used for EPA Method 1668C PCB Congener Analysis.....	49
Table 24.	PCBs QA/QC Frequency and Acceptance Criteria .....	49
Table 25.	KCEL and EIM Equivalent Data Qualifiers.....	54
Table 26.	Pacific Rim Laboratory Data Qualifiers .....	55

## Appendices

---

Appendix A: Stormwater Treatment Installation Designs

Appendix B: Chain of Custody Forms

# APPROVALS

---

SIGNED	6/10/2015
Carly Greyell, King County Project Manager	Date
SIGNED	6/10/2015
Deb Lester, King County Toxicology and Contaminant Assessment Supervisor	Date
SIGNED	6/10/2015
Colin Elliott, King County Environmental Laboratory Quality Assurance Officer	Date
SIGNED	6/15/2015
Brandi Lubliner, Washington State Department of Ecology	Date
SIGNED	6/19/2015
Bill Moore, Washington State Department of Ecology	Date

## **Certification**

I certify under penalty of law, that this document and all attachments were prepared under my direction or supervision in accordance with a system designed to assure that qualified personnel properly gathered and evaluated the information submitted. Based on my inquiry of the person or persons who manage the system or those persons directly responsible for gathering information, the information submitted is, to the best of my knowledge and belief, true, accurate and complete. I am aware that there are significant penalties for submitting false information, including the possibility of fine and imprisonment for willful violations.

## **Distribution List**

Brandi Lubliner	Washington Department of Ecology
Karen Dinicola	Washington Department of Ecology
Fritz Grothkopp	King County Environmental Laboratory
Eric Gilmore	City of Shoreline
Fred Bergdolt	Washington State Department of Transportation

# 1.0 BACKGROUND

---

Untreated stormwater has been identified as a major contributor of contaminants and habitat degradation in urban water bodies (EPA 1999, McIntyre et al. 2015). As new stormwater controls and treatment facilities are implemented, it is necessary to assess their effectiveness in the field and their potential to improve water quality in receiving water bodies. This study evaluates the effectiveness of stormwater treatment facilities recently added along the Aurora Corridor (part of State Route 99) in Shoreline, Washington, where highway, commercial and residential stormwater is received by Echo Lake. The goals of the Aurora Corridor Project include improving traffic safety, traffic flow, streetscape amenities, and stormwater quality along the three-mile stretch of the Aurora highway within the City of Shoreline. Construction within the Echo Lake drainage basin began in 2011 and is scheduled to be completed at the end of 2015.

This study was designed to address data gaps identified by the Washington State Stormwater Work Group (SWG) in the effectiveness of stormwater treatment technologies used in the Puget Sound Region. The SWG represents several layers of government, economic stake holders, and researchers, and was formed under the leadership of the Puget Sound Partnership (PSP) and Washington State Department of Ecology (Ecology) in 2008 to develop a Stormwater Monitoring and Assessment Strategy for the Puget Sound Region. The Regional Stormwater Monitoring Program (RSMP), through which this and several other effectiveness studies are funded, was created out of this process.

This site was selected because Echo Lake is part of an ongoing long-term monitoring program and the stormwater treatment design allows sampling of stormwater both before and after enhanced treatment<sup>1</sup>. The SWG identified testing the effectiveness of Low Impact Development (LID) technology for treating stormwater in the field as a study need. The bioretention planter boxes monitored for the project are underdrained, which facilitates monitoring, but precludes LID designation. Studying the effectiveness of Best Management Practices (BMPs) providing enhanced treatment is presumed to still be of interest to the SWG and municipal stormwater permittees.

## 1.1 Study Area

Echo Lake is a small stormwater-fed lake that drains to the larger Lake Ballinger, and is part of the McAleer Creek basin. The Echo Lake drainage basin is about 215 acres and comprised of seven stormwater conveyance subbasins. Land use in this basin is predominantly urban with commercial and residential use, and over 56% impervious surface (HDR 2011). The Aurora Corridor runs north to south within about 350 feet of the

---

<sup>1</sup> Enhanced treatment has a goal of increased reduction in dissolved metals as compared to basic treatment, currently defined as greater than 30% removal of dissolved copper and greater than 60% removal of dissolved zinc. This applies to influent concentrations within the range of 0.005 to 0.02 mg/L dissolved copper, and 0.02 to 0.3 mg/L dissolved zinc. Basic treatment should achieve at least 80% removal of total suspended solids for influent concentrations greater than 100 mg/L (Ecology 2011).

western edge of Echo Lake. The urban setting of this study area may require traffic control and confined space training to conduct sampling (See Section 6.4). Figure 1 depicts the subbasin boundaries and Figure 2 illustrates the Echo Lake drainage basin and current land use.

### 1.1.1 Contaminants of Interest

Stormwater from urban areas generally contains a wide-range of pollutants including nutrients, bacteria, metals and various organic contaminants (Hobbs et al. 2015). Residential yards and a large commercial garden center are likely sources of nutrients, including phosphorus, in stormwater runoff in the Echo Lake basin. Phosphorus is a limiting factor for algal growth in Echo Lake. Excess phosphorus can result in increased algal blooms, which can result in anoxic conditions in the lake. Echo Lake consistently has low dissolved oxygen (DO) during the summer months (King County 2014a).

Increased sediment inputs from stormwater can negatively impact aquatic life and water clarity. Additionally, many contaminants are associated with sediment; reducing total suspended solids (TSS) in stormwater is often correlated with a reduction in sediment associated contaminants (e.g., nutrients, metals and organics). Sediment in runoff can originate from impervious surfaces or soil erosion.

Bacteria are also commonly found in urban and residential stormwater, and can limit the use of small lakes. Echo Lake has been listed as a Category 2, or waters of concern, due to fecal coliform contamination [Ecology 303(d) Listing ID 12156].

Since the lake is stormwater-fed, other common stormwater contaminants are likely present; however, the lake has not been regularly monitored for metals or organic contaminants. Heavy metals, including copper, lead and zinc are commonly detected in road runoff at levels of ecological concern (EPA 1999). Polycyclic aromatic hydrocarbons (PAHs) are common contaminants in roadway runoff, and are suspected to cause stormwater toxicity (McIntyre et al. 2015). Polychlorinated biphenyls (PCBs) are of major concern for several larger water bodies in the Greater Seattle area for both wildlife and human health endpoints (e.g., Lake Washington and the Lower Duwamish Waterway). A recent King County study found local drainage was the major pathway for PCBs to enter Lake Washington (King County 2013), where fish advisories limit the consumption of some species due to elevated PCB levels. There is a need for research on the effect of current stormwater treatment technologies on PCB removal from stormwater, as local and state entities work towards improving ambient PCB concentrations in local waterbodies. Water quality monitoring in the Echo Lake drainage basin has not included PCB analysis.



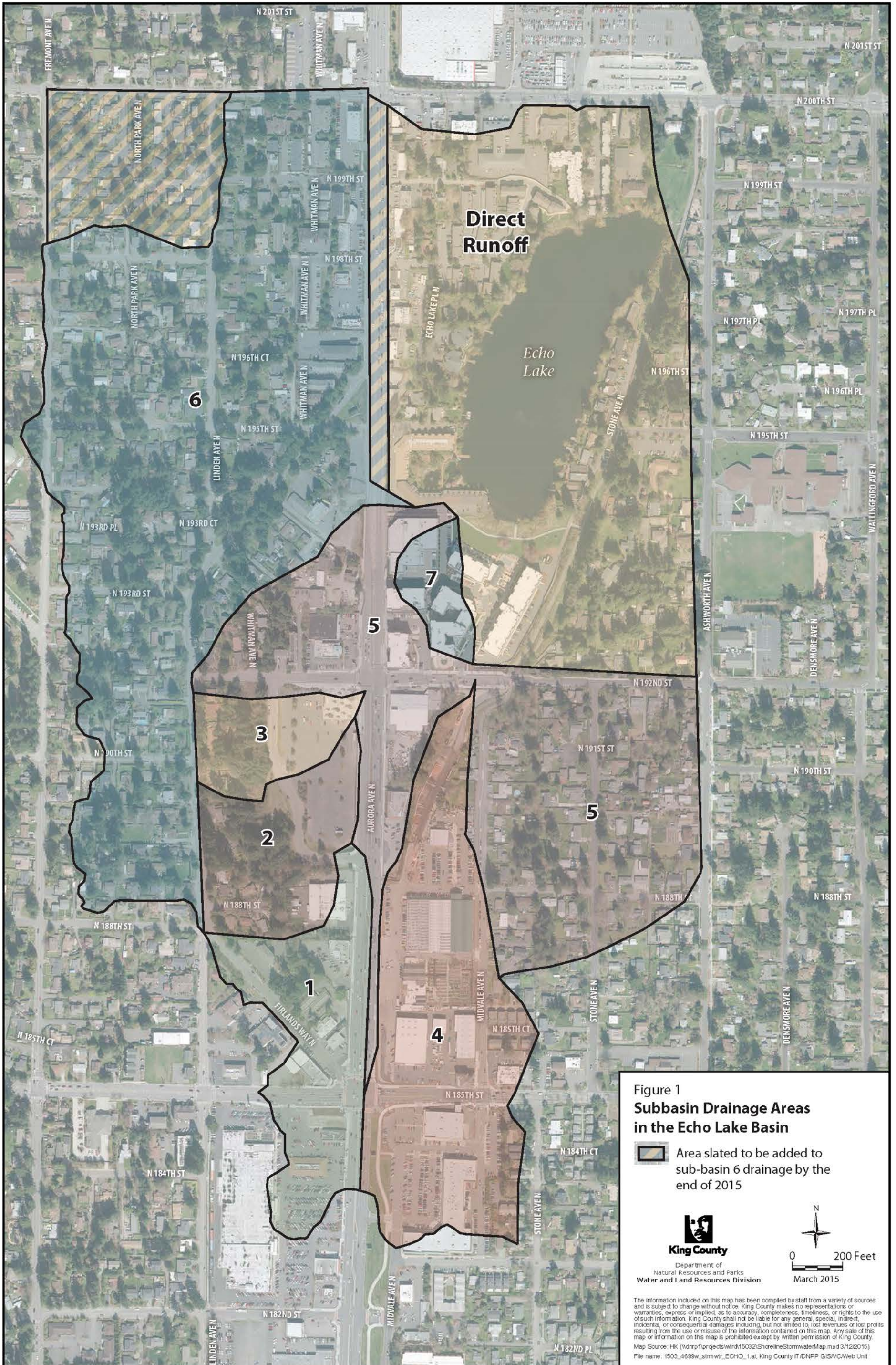



This page intentionally left blank.



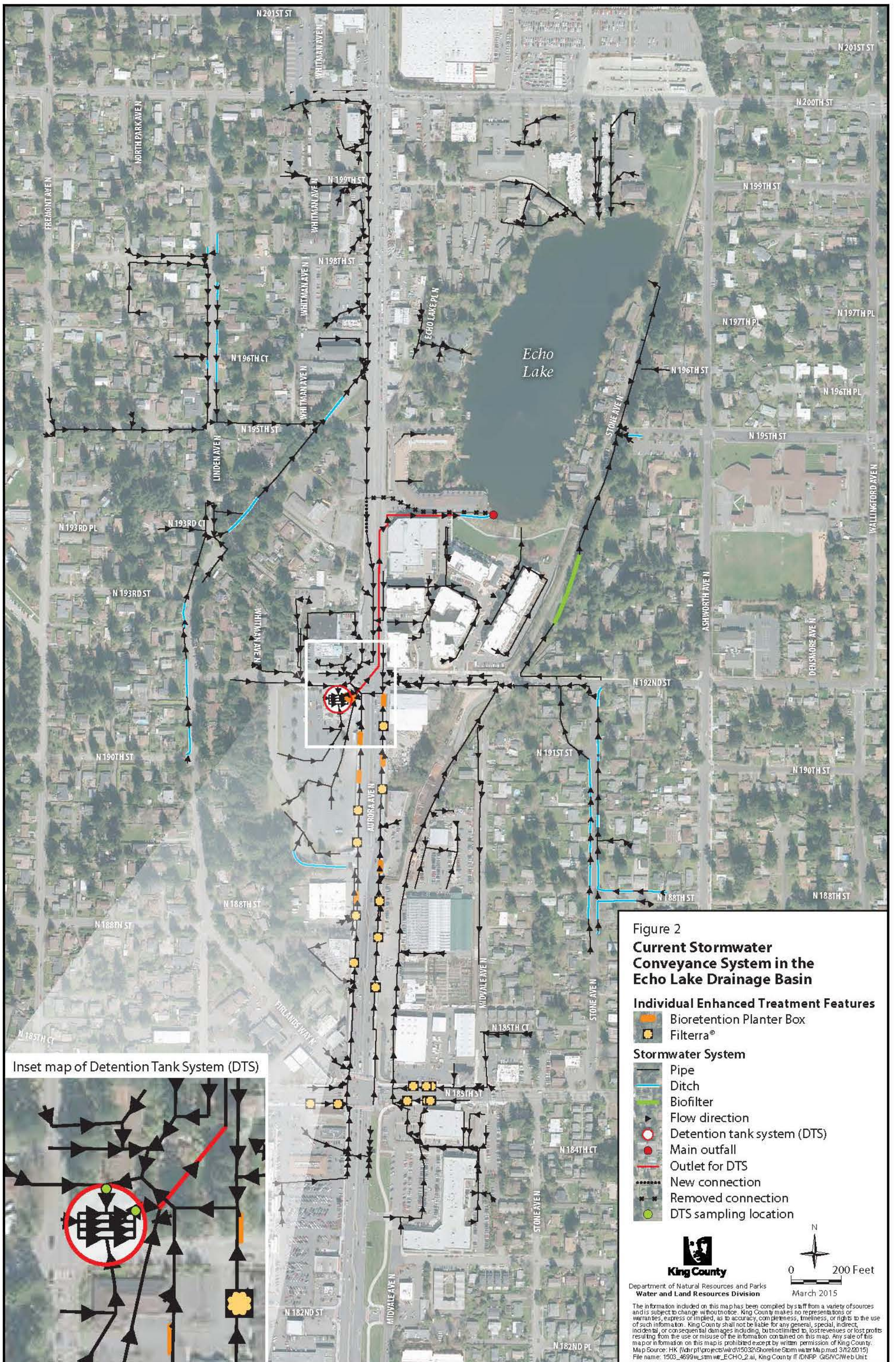



This page intentionally left blank.

### 1.1.2 Changes in Stormwater Infrastructure

Prior to the current retrofit, stormwater from the Aurora Corridor received no targeted water quality treatment before being piped directly to Echo Lake. Figure 1 shows the seven subbasins that comprise the piped stormwater system in the Echo Lake drainage basin. Prior to the fourth quarter of 2014, subbasins 1 through 5 drained to an outfall in the southwest corner of the lake (main outfall), while subbasin 6 drained to a parallel outfall (Figures 1 and 2). Subbasin 7 drains to a separate outfall in the southeast corner of the lake, and is not included in the study area. This subbasin contains mostly private property and while some private retrofitting has occurred over the years, including ditches and bioswales, the separate outfall has been maintained. In December 2014, the retrofit combined subbasin 6 with the stormwater system of subbasins 1 through 5 as shown in Figure 2. A small portion of subbasin 6 has historically drained directly to Lake Ballinger, but will be completely rerouted to the subbasin 6 drainage by the end of 2015.

In 2012, construction along the Aurora Corridor added enhanced treatment for 1.6 acres of impervious roadway surfaces in subbasins 1, 3, 4 and 5, with all but 0.5 of these acres also receiving phosphorus treatment<sup>2</sup>. By the end of 2015, 1.3 acres of impervious highway surfaces in subbasin 6 will have enhanced treatment, with all but 0.5 of these acres also receiving phosphorus treatment. The treated 2.9 acres represents a mixture of new and existing impervious surfaces. Enhanced stormwater treatment was required by the National Pollutant Discharge Elimination System (NPDES) Phase II Municipal Stormwater Permit as part of the Aurora Corridor Project (HDR 2011) and is being installed according to the 2005 Stormwater Management Manual for Western Washington (SWMMWW; Ecology 2005). A stormwater detention tank system (DTS) was added to provide flow control to stormwater in route to Echo Lake through the southwest outfall. Table 1 summarizes all stormwater treatment additions to this system.

**Table 1. Stormwater Treatment Technologies Added in the Echo Lake Drainage Basin.**

Installation	Type of Treatment	Subbasins 1 through 5 (Construction Completed 2012)	Subbasin 6 (Construction to be Completed in 2015)
		Acres Treated	Acres Treated
Bioretention Planter Boxes	Enhanced	0.55	0.47
Filtterra®	Enhanced and Phosphorus <sup>a</sup>	1.08	0.78

<sup>a</sup>In 2009, the Filtterra® design was approved for basic, enhanced and oil treatment under the General Use Level Designation (GULD) and approved for phosphorus treatment under the Conditional Use Level Designation (CULD). In 2014, the phosphorus treatment was approved for GULD (Ecology 2015).

<sup>2</sup> Phosphorus treatment has a goal of 50% total phosphorus removal in addition to basic treatment (for influent concentrations of 0.1 to 0.5 mg/L total phosphorus) (Ecology 2008).

## 1.2 Previous Stormwater Sampling Efforts

In response to eutrophic conditions in Echo Lake, the City of Shoreline conducted a stormwater quality assessment of the Echo Lake subbasins (Figure 1) in 2004 (Shoreline, 2005). Samples (composites of three grab samples) were collected at the most downstream point of all seven subbasins during three storms in March and May 2004. Table 2 summarizes results for the available parameters of interest analyzed during this sampling effort.

**Table 2. Summary of Stormwater Quality Across All Seven Subbasins Sampled within the Echo Lake Drainage Basin (2004).**

Group	Parameter	Method	Units	FOD	Minimum	Maximum	Average	RSD
Conventionals/ Nutrients	TSS	EPA 160.2	mg/L	21/21	1.00	236	53.4	1.3
	Total Phosphorus	EPA 365.1	mg/L	21/21	0.021	1.14	0.264	1.3
	Total Nitrogen	SM(20)4500-N	mg/L	21/21	0.329	6.54	1.90	0.8
Metals	Total Copper	EPA 220.0	µg/L	21/21	2.9	187	37.9	1.4
	Total Lead	EPA 239.2	µg/L	17/21	ND	25.4	8.6 D	0.7
	Total Zinc	EPA 200.7	µg/L	21/21	6.6	211	86.0	0.7
Organics	Diesel-Range Hydrocarbons	NWTPH-Dx (Ecology 1997)	mg/L	4/21	0.06	0.15	0.09	0.5
	Lube Oil-Range Hydrocarbons	NWTPH-Dx (Ecology 1997)	mg/L	21/21	0.01	0.015	2.1	0.6

\* Summary statistics include detected results only;

ND – non-detect; D – indicates calculated with detected values only

FOD – frequency of detection; RSD – relative standard deviation;

Concentrations of TSS, nutrients and metals were almost always lowest in samples collected from Basins 2 and 3, and highest in Basin 4. Lube oil-range hydrocarbon concentrations were consistently lowest in samples collected from Basin 3. At the time of sampling, stormwater from Basin 2 passed over a basic biofiltration swale<sup>3</sup> to slow flow and remove some pollutants, and Basin 3 has the least amount of impervious area (1.3 acres). These factors likely contributed to the relatively low chemical concentrations in these basins. Most of the stormwater from basin 4 originates from the large garden center and surrounding parking lot. At the time of sampling, exposed compost and soil piles, as well as the use of fertilizers and pesticides on site, may have been sources of TSS, nutrients and metals. Since 2004, actions have been taken to reduce stormwater pollutants from the garden center.

<sup>3</sup> A basic biofiltration swale is a type of biofilter, which are vegetated treatment systems (typically grass) that remove pollutants by means of sedimentation, filtration, soil sorption, and/or plant uptake (BMP T9.10 of the SWMMWW, Ecology 2012).

In addition to the water quality evaluation described above, grab samples were collected from the main outfall during five storms between November 2010 and January 2011 (Figure 2) (Shoreline, unpublished data). These samples were analyzed by the King County Environmental Laboratory (KCEL) for a similar suite of parameters, but also included measurement of dissolved metals. At the time of sampling, this outfall received stormwater from subbasins 1 through 5. Until 2012, none of the stormwater received secondary treatment or targeted water quality treatment. Table 3 summarizes results for the available parameters of concern analyzed during this sampling effort.

**Table 3. Summary of Stormwater Quality at Echo Lake's Southwest Stormwater Outfall (2010-2011)**

Group	Parameter	Method	Units	FOD	Minimum	Maximum	Average	RSD
Conventionals/ Nutrients	TSS	SM2540D	mg/L	5/5	20.2	88.2	43.3	0.65
	Total Phosphorous	SM4500-P-B, F	mg/L	5/5	0.0897	0.149	0.124	0.20
	Orthophosphate	SM4500-P-F	mg/L	5/5	0.0324	0.0563	0.0407	0.23
Metals	Dissolved Copper	EPA 200.8	µg/L	5/5	3.8	11.9	7.6	0.40
	Total Copper	EPA 200.8	µg/L	5/5	12.1	25.4	17.9	0.28
	Dissolved Zinc	EPA 200.8	µg/L	5/5	45.4	122	72.7	0.43
	Total Zinc	EPA 200.8	µg/L	5/5	75.6	165	117	0.28
Organics	Diesel-Range Hydrocarbons	NWTPH-Dx (Ecology 1997)	mg/L	2/5	0.213	0.215	0.214	0.01
	Lube Oil-Range Hydrocarbons	NWTPH-Dx (Ecology 1997)	mg/L	5/5	0.368	1.14	0.730	0.48
	Volatile Petroleum Products	NWTPH-Gx (Ecology 1997)	mg/L	0/5	ND	ND	ND	ND
	Total LPAHs	SW846-8270D SIM	µg/L	17/30	0.035	0.261	0.109	0.84
	Total HPAHs	SW846-8270D SIM	µg/L	46/50	0.190	1.03	0.475	0.69

\* Summary statistics include detected results only; FOD for PAHs reflects detections of individual compounds in all five samples;

FOD – frequency of detection; RSD – relative standard deviation; ND – non-detects  
LPAHs – low molecular weight PAHs; HPAHs- high molecular weight PAHs.

Conventional parameters, nutrients and metals were detected in all samples, and all organic compounds were detected at least once, with the exception of volatile petroleum products. Total suspended solids and PAHs had the highest relative variability in concentration, whereas metal and nutrient concentrations were less variable.

## 2.0 PROJECT DESCRIPTION

---

This study will evaluate the effectiveness of stormwater treatment facilities newly added along the Aurora Corridor in Shoreline, where highway runoff is received by Echo Lake. The project goals are to evaluate individual treatment features, as well as the system as a whole, for their ability to improve the quality of stormwater runoff and reduce peak flows. The objectives are as follows:

### **Individual Treatment Features:**

Objective 1 - Evaluate the effectiveness of individual enhanced stormwater treatment installations at reducing solids, nutrients, bacteria, metals, select organic contaminants and toxicity in highway runoff in Shoreline.

### **System-wide:**

Objective 2 - Evaluate the flow control benefits of the system-wide stormwater DTS, and any additional reduction of solids, nutrients, bacteria, metals and select organic contaminants that occur.

Objective 3 - Assess changes in stormwater quality in this system by comparing historical stormwater data to current stormwater quality before and after treatment.

Objective 4 - Identify if nutrient and bacteria levels have changed in Echo Lake over time, and how these changes correspond to changes in stormwater infrastructure in the contributing basin. The purpose of this analysis is to consider potential effects to the receiving water body as a piece of the discussion, not to establish a causal relationship.

The following sections describe the approach to completing these objectives.

### 2.1 Sampling Individual Treatment Features

The first study objective will be met by collecting composite grab samples at the inlet and outlet of six individual enhanced treatment features along the Aurora Corridor during six to eight storms. These methods are detailed in Section 6.1. Each composite sample will be analyzed for conventional parameters, nutrients, bacteria, total and dissolved metals, PAHs and diesel- and lube oil-range hydrocarbons (NWTPH-Dx). The specific analytes are listed in Section 5.3. During three storm events, PCB congeners will also be analyzed. Toxicity testing (acute *Daphnia pulex* and chronic *Ceriodaphnia dubia*) will also be conducted with samples collected at the inlet and outlet of one bioretention planter box during four storm events. A statistical comparison of influent and effluent results will determine treatment effectiveness. Influent and effluent concentrations may also be compared to historical data from spatially-relevant basins to address Objective 3, although statistical power may be limited.



## 2.2 System-wide Evaluation

The system-wide evaluation will include collection of influent and effluent samples at the DTS for 12 to 14 storms. Sample collection and analysis in Echo Lake will be conducted through the ongoing King County Lake Stewardship Program. This program monitors Echo Lake for fecal coliform, nitrogen, phosphorus, chlorophyll- $\alpha$  and phaeophytin (a degradate of chlorophyll) biweekly between May and October each year. In conjunction with the Lake Stewardship Program, historical Echo Lake monitoring data will be compiled from 2000 to the present and evaluated for changes over time.

### 2.2.1 Detention Tank System

Flow meters will be installed at the most representative inlet and outlet points<sup>4</sup> of the DTS to collect continuous flow data. The DTS is located at the King County Metro Park & Ride at the southwest corner of N 192<sup>nd</sup> Street and the Aurora highway. This structure releases to the southwest outfall in Echo Lake, which currently captures runoff from basins 1 through 6 (Figure 2). The DTS was designed to provide flow control for all new impervious surfaces resulting from the Aurora Corridor Improvement Project. The Western Washington Hydrology Model was used to model runoff quantities and to appropriately size this system (HDR 2011).

Flow data will be collected for several months prior to initiation of stormwater sampling, as flow conditions will have implications for programming the sampling equipment. ISCO<sup>®</sup> Autosamplers will be installed to collect flow-weighted composite samples during 12 to 14 storms for the 2015/2016 storm season<sup>5</sup>. However, samples will only be collected after construction is complete, which could delay the start of sampling to January 2016 at the latest. All samples will be analyzed for conventional parameters, nutrients, bacteria, total and dissolved metals, PAHs and NWTPh-Dx. The specific analytes are listed in Section 5.3. Samples from three storm events will be analyzed for PCBs. A statistical comparison of influent and effluent results will address Objective 2. Statistical methods and the limitations to this analysis are discussed in Section 10. Influent and effluent concentrations may be compared to historical outfall samples, satisfying Objective 3; however, these results must be compared with caution as described in Section 5.5 and 10.

---

<sup>4</sup> Two small subbasins (2 and 3) join the DTS infrastructure at points other than the main inlet and outlet, and will not be sampled by this monitoring effort. Specifically, stormwater from subbasin 2 drains into the system after the main DTS outlet point, and stormwater from subbasin 3 enters the flow control portion of the DTS from a different inlet. Subbasins 2 and 3 make up the Park-and-Ride parking lot, and are small in comparison to the other subbasins incorporated by the DTS (6% and 3% of the total area, 4.7 and 8.3 acres, respectively). During the 2004 sampling effort described in Section 1.2, stormwater samples from these subbasins had the lowest concentrations for most analyzed parameters. While stormwater from these subbasins reaches the lake, they are not expected to substantially influence concentrations in the system, and will not be monitored as part of this project.

<sup>5</sup> The number of storms listed here was not statistically derived, but determined by the maximum number of storms the field team can feasibly sample in the given storm season. The number of storms feasibly sampled at the DTS is greater than the number at the individual enhanced treatment features, because autosamplers do not require the team to be onsite during collection.

## 2.2.2 Ongoing Echo Lake Monitoring

The King County Lake Stewardship Program will collect bi-weekly ambient water samples from Echo Lake from May to October. The sampling location for these samples is centered over the deepest point of the lake; nearly bisecting North 195<sup>th</sup> Street if it continued across the lake (See Figure 2 for context). Grab samples are collected from 1.0, 4.0, and 8.5 meter depths and analyzed for bacteria, nutrients and indicators of algal growth, including chlorophyll- $\alpha$ . Field measurements include DO, temperature, and Secchi depth, which provide context for the analytical results. These and previously collected data will be analyzed to assess trends and address Objective 4. This portion of the study is meant to compliment the assessment of effectiveness of individual treatment features in the basin. While there is an interest in what impact this retrofit may have on the receiving water body, the area with stormwater treatment is relatively small compared to the overall drainage area of the basin. Several factors may confound this analysis; therefore, the goal is not to establish a causal link between changes in stormwater infrastructure and water quality in the receiving water body, but to leverage existing data to add a discussion of changes in water quality, or lack thereof, as changes in stormwater infrastructure have occurred in the basin.

## 3.0 ORGANIZATION AND SCHEDULE

---

The project team consists of personnel from two sections within King County's Water and Land Resources Division (WLR Division), partners from the City of Shoreline, an RSMP coordinator from Ecology, and an RSMP technical liaison from Washington State Department of Transportation (WSDOT). The contracted laboratory, Pacific Rim Laboratories, will conduct PCB congener analysis, and a contracted validator will conduct PCB congener data validation. Team members with an asterisk by their name will be in regular contact to coordinate the sampling and analysis effort, and ensure adherence with the plan described in this Quality Assurance Project Plan (QAPP).

### **King County WLR Division, Science Section**

- Carly Greyell – Project Manager\*
- Jenée Colton – Technical Assistance
- Kate Macneale – Technical Assistance
- Richard Jack – Technical Assistance, PCB Data Management
- Deborah Lester – Toxicology and Contaminant Assessment Unit (TCA) Supervisor

*This group is responsible for project planning, communicating between involved parties, and validating, synthesizing and communicating results.*

### **King County WLR Division, KCEL**

- Fritz Grothkopp – Laboratory Project Manager (LPM)\*
- Colin Elliott – Quality Assurance Officer
- Analytical Group
- Diane McElhany – Metals and Organics Laboratory Supervisor
- Brian Prosch – Conventional Laboratory Supervisor
- Eric Thompson – Microbiology Laboratory Supervisor
- Fran Sweeney – Aquatic Toxicology Supervisor
- Field Science Unit
- Ben Budka – Field Science Unit (FSU) Supervisor\*
- Christopher Barnes – Field Technician

*This group is responsible for all field work, analyzing samples for all parameters except PCBs, shipping samples to Pacific Rim for PCB analysis, KCEL data management and data review.*

### **City of Shoreline, Public Works**

- Melissa Ivancevich – Water Quality Specialist\*
- Eric Gilmore – Senior Engineering Technician\*

*This group is responsible for providing logistical support for field sampling and site-specific technical expertise.*

## RSMP Representatives

- Brandi Lubliner, Ecology – RSMP Coordinator
- Fred Bergdolt, WSDOT – RSMP Technical Liaison

*This group is responsible for providing coordination between the SWG and the rest of the project team, as well as technical oversight.*

Table 4 lists the contact information for all project team members.

**Table 4. Team Member (and Outside Contract\*) Contact Information**

Organization	Name	Contact Information
King County	Carly Greyell	206-477-4703; carly.greyell@kingcounty.gov
King County	Jenée Colton	206-477-4075; jenee.colton@kingcounty.gov
King County	Kate Macneale	206-477-4769; kate.macneale@kingcounty.gov
King County	Richard Jack	206-477-4715; richard.jack@kingcounty.gov
King County	Deborah Lester	206-477-4752; deborah.lester@kingcounty.gov
King County	Fritz Grothkopp	206-477-7114; fritz.grothkopp@kingcounty.gov
King County	Colin Elliott	206-477-7113; colin.elliott@kingcounty.gov
King County	Diane McElhany	206-477-7175; diane.mcelhany@kingcounty.gov
King County	Brian Prosch	206-477-7125; brian.prosch@kingcounty.gov
King County	Eric Thompson	206-477-7165; eric.thompson@kingcounty.gov
King County	Fran Sweeney	206-477-7117; francis.sweeney@kingcounty.gov
King County	Ben Budka	206-477-7142; ben.budka@kingcounty.gov
King County	Christopher Barnes	206-477-7143; christopher.barnes@kingcounty.gov
City of Shoreline	Eric Gilmore	206-801-2454; egilmore@shorelinewa.gov
City of Shoreline	Melissa Ivancevich	206-801-2453; minvancevich@shorelinewa.gov
Ecology	Brandi Lubliner	360-407-7140; brandi.lubliner@ecy.wa.gov
WSDOT	Fred Bergdolt	360-570-6648; bergdof@wsdot.wa.gov
Pacific Rim Laboratories*	David Hope	1-604-532-8711; david@pacificrimlaboratories.com

Table 5 details the project schedule and deliverable due dates.

**Table 5. Schedule of Tasks**

Activity	Anticipated Date of Initiation	Anticipated Date of Completion	Deliverable	Deliverable Due Date
<b>TASK 2.0 – Field Sampling and Analysis</b>				
Continuous Flow Monitoring at DTS (inlet & outlet)	Feb. 2015	June 2016	Documenting Progress Reports	Semi-annually
Storm Sampling (8 to 12 storm events)	Nov. 2015	June 2016	Documenting Progress Reports	Semi-annually
Analysis at KCEL and Pacific Rim Laboratories	Nov. 2015	Dec. 2016	Documenting Progress Reports	Semi-annually
<b>TASK 3.0 – Summary of Echo Lake Historical Data</b>				
Developing Draft Technical Memo	July 2015	Sept. 2015	Draft Memo	Sept. 2015
Finalizing Technical Memo	Sept. 2015	Nov. 2015	Final Memo	Nov. 2015
<b>TASK 4.0 – Final Report</b>				
Draft Writing	Aug. 2016	April 2017	Documenting Progress Reports	Semi-annually
Data Analysis	Nov. 2016	March 2017	Documenting Progress Reports	Semi-annually
Final Draft Report	April 2017	May 2017	Draft Report	May 2017
Final Report	May 2017	July 2017	Final Report	July 2017
<b>TASK 5.0 – Distribution of Findings</b>				
Submit ambient lake data to EIM	Sept. 2016	Dec. 2017	Data submitted	Dec. 2017
Submit system data to National BMP database	Sept. 2016	Dec. 2017	Data submitted	Dec. 2017
Presentations (2 total)	Sept. 2016	Dec. 2017	Copies of presentations	Dec. 2017
Website Development	Feb. 2015	Dec. 2017	1. Post QAPP 2. Post Technical Memo 3. Post Final Report	June 2015 Dec. 2015 Dec. 2017
<b>TASK 6.0 – Project Management</b>				
Project management	Jan. 2015	Dec. 2017	Documenting Progress Reports	Semi-annually

EIM – Environmental information Management System

The sampling and analysis schedule is dependent on the timing of suitable storms; therefore, the proposed schedule is subject to change.

## 4.0 QUALITY OBJECTIVES

---

The data quality objectives (DQOs) for this effort are to collect data of known and sufficient quality to meet study goals. The data quality indicators of precision, bias, sensitivity and accuracy are described within this section, while representativeness, comparability, completeness are described in Section 5, after the details of the sampling design. Detailed descriptions and specific limits for quality assurance/quality control (QA/QC) samples are discussed in Section 8.

### 4.1 Precision

Precision is the agreement of a set of results among themselves and is a measure of the ability to reproduce a result. For this project, evaluation of precision will be based on field replicates, laboratory duplicates or triplicates and matrix spike duplicates. Differences between results for these QA/QC samples must be within the criteria presented in Section 8 to meet measurement quality objectives (MQOs).

### 4.2 Bias

Bias is a measure of the difference, due to a systematic factor, between an analytical result and the true value of an analyte. Bias will be evaluated by analyzing field blanks, method blanks, spike blanks, matrix spikes, certified reference materials, laboratory control samples and/or surrogates, along with ongoing recovery sample control charts. Results for these QA/QC samples must be within the criteria presented in Section 8 to meet MQOs.

### 4.3 Sensitivity

Sensitivity is a measure of the capability of analytical methods to meet the study goal. The analytical method detection limits (MDLs) presented in Section 7 are sensitive enough to detect conventional parameters, total and dissolved metals, low level PAHs and PCB congeners at concentrations sufficient to increase the understanding of the effect of stormwater treatment on concentrations of these parameters within the Echo Lake basin.

The standard MDLs for TSS and nutrients were between two and 40 times below minimum concentrations in stormwater previously analyzed from this site, as presented in Tables 2 and 3. Previously reported metals concentrations were all greater than the standard MDLs for this study. Occasionally, due to dilution during analysis, MDLs may be elevated; however, for these parameters, detections are expected for all influent samples.

Organic parameters are less commonly detected; however, the standard MDLs for the PAHs were almost 10 times greater than the detected concentrations in previously collected stormwater samples from the southwest outfall to Echo Lake. Stormwater has been found to be a major pathway of PCBs (King County 2013) and the analytical method being used for PCB congeners is a rigorous, low-level method for water samples. While PCBs have not

previously been analyzed at this site, they will be reported as a sum of all congeners for this project. It is expected that many congeners will not be detected, but at least a few will be detected in each sample.

## 4.4 Accuracy

Accuracy is an estimate of the difference between the true value and the measured value. The accuracy of a result is affected by both systematic and random errors. Accuracy of the field measurements (listed in Section 5.3) will be assessed by replicate measurements, and accuracy of the flow data will be verified by hand measurements of water level depth (Section 8.9). Accuracy of the analytical results will be evaluated using field blanks, method blanks, matrix spikes, certified reference materials and/or laboratory control samples, along with ongoing recovery sample control charts. Results for these QA/QC samples must be within the criteria presented in Section 8 to meet MQOs. Additionally, the isotopic dilution method chosen for this study is the most rigorous method for PCB congener analysis. This method uses isotopically-labeled congeners, to track the recovery performance of the range of congener homologs. Thus, each congener concentration is theoretically adjusted for the extraction efficiency and analytical performance of that specific sample.

## 5.0 SAMPLING DESIGN

The goals of this study are to evaluate the effectiveness of various stormwater treatment features in improving stormwater quality on both an individual and system-wide level. The following sections describe the sampling design to achieve these study goals.

### 5.1 Site Description

Sampling locations are listed in Table 6 and depicted in Figure 2. Exact bioretention planter box and Filterra® installations to be monitored are subject to change based on field conditions after construction is completed. Influent and effluent samples will be collected from the bioretention planter boxes and Filterras® with peristaltic pumps. Designs for both treatment structure types are included as Appendix A, with labelled sampling access points. All bioretention planter boxes and Filterra® units included in this study receive direct runoff from the Aurora highway. Bioretention planter boxes are expected to provide enhanced stormwater treatment (i.e., a reduction in suspended solids and metals) while Filterras® are designed to also reduce phosphorus.

Echo Lake has a surface area of 12 acres with mean and maximum depths of 14 and 30 feet, respectively. The land use directly surrounding the lake is mostly residential, but it receives stormwater piped from impervious surfaces in commercial areas and the highway, primarily through the southwest outfall. The DTS infrastructure currently intercepts stormwater from subbasins 1 through 6, prior to discharge at this outfall<sup>6</sup>. Land use in these subbasins includes highway, parking lots, residential and commercial areas. Autosamplers will collect flow-weighted composite samples at the inlet and outlet of the DTS. Flow will be continuously monitored at these locations, throughout the project period.

**Table 6. Sample Locations**

Locator ID	Description	Latitude, Longitude
ECHO-BP1-In ECHO-BP2-In ECHO-BP3-In ECHO-BP4-In	Inlet of four bioretention planter boxes, constructed in 2012 (n=2) and 2015 (n=2)	To be determined after construction
ECHO-BP1-Out ECHO-BP2-Out ECHO-BP3-Out ECHO-BP4-Out	Outlet of same four bioretention planter boxes, constructed in 2012 (n=2) and 2015 (n=2)	To be determined after construction
ECHO-FLT1-In ECHO-FLT2-In	Inlet of two Filterra®, constructed in 2012 (n=1) and 2015 (n=1)	To be determined after construction
ECHO-FLT1-Out ECHO-FLT2-Out	Outlet of same two Filterra®, constructed in 2012 (n=1) and 2015 (n=1)	To be determined after construction

<sup>6</sup> Subbasin 2 enters the system after the DTS flow control structure, but prior to the outfall.



Locator ID	Description	Latitude, Longitude
ECHO-DTS-In	Echo Lake stormwater - Inlet of DTS	47.767697, -122.346477
ECHO-DTS-Out	Echo Lake stormwater - Outlet of DTS	47.767634, -122.346277

## 5.2 Qualifying Storm Event Criteria for Sampling

One challenging aspect of stormwater sampling is storm variability. The use of storm criteria increases the chances that sampling equipment is only deployed when stormwater flows will result in sufficient sample volume. The criteria presented below have been adapted from the Technology Assessment Protocol – Ecology (TAPE) *Guidance for Evaluating Emerging Stormwater Treatment Technologies* (Ecology 2011). These criteria may be modified based on preliminary flow monitoring in the stormwater system.

### Storm Event Guidelines:

- Rainfall during storm event: at least 0.15 inches, no fixed maximum
- Rainfall duration: at least one hour, no fixed maximum
- Antecedent dry period: at least six hours with less than 0.04 inches of rain
- Flow requirements: Effluent must be flowing from outlet locations

## 5.3 Measured Parameters

The following field measurements will be collected at each location during each sampling event:

- Dissolved oxygen
- Temperature
- pH
- Turbidity
- Conductivity

Conventional parameters, nutrients and bacteria to be analyzed in the laboratory for each stormwater sample are as follows:

- Total suspended solids
- Hardness
- Ortho-phosphate
- Total phosphate
- Total organic carbon (DTS effluent only)
- Dissolved organic carbon (DTS effluent only)
- Ammonia
- Nitrite/nitrate
- Total nitrogen
- Fecal coliform

Total and dissolved metals analysis will include:

- Cadmium
- Copper
- Lead
- Zinc

Organics analysis will include:

- 1-Methylnaphthalene
- 2-Methylnaphthalene
- Acenaphthene
- Acenaphthylene
- Anthracene
- Benzo(a)anthracene
- Benzo(a)pyrene
- Benzo(b,j,k)fluoranthene
- Benzo(g,h,i)perylene
- Chrysene
- Dibenzo(a,h)anthracene
- Fluoranthene
- Fluorene
- Indeno(1,2,3-Cd)pyrene
- Naphthalene
- Phenanthrene
- Pyrene
- Diesel-range hydrocarbons
- Lube oil-range hydrocarbons
- PCB congeners

Toxicity tests will include:

- Chronic *Ceriodaphnia dubia* (7-day static-renewal reproduction and survival tests)
- Acute *Daphnia pulex* (48-hour static survival test)

## 5.4 Representativeness

Representativeness expresses the degree to which sample data accurately and precisely represent a characteristic of a population, parameter variations at the sampling point, or an environmental condition. Samples are to be collected in such a manner as to minimize potential contamination and other types of degradation in the chemical and physical composition of the water. This can be achieved by following guidelines for sampler decontamination, sample acceptability criteria, sample processing, observing proper hold-times, preservation, and storage of samples, as described in Sections 6 and 7. In order to reduce the risk of cross-contamination between sampling locations, all tubing (sampling and sample splitting tubing) will be pre-cleaned and either new or dedicated to a particular site, as described in Section 6. In order to better estimate average conditions in the stormwater system, a range of storm intensities will be targeted. The samples are intended to generate data of sufficient quality to allow analysis of treatment effectiveness for the parameters listed in Section 5.3.

There are a few issues regarding representativeness for samples collected at the DTS system. First, the DTS receives stormwater inputs from subbasin 3, which are not captured at the inlet sampling location (ECHO-DTS-In). As discussed in the footnote in Section 2.2.1, all outflow is monitored, but the true inflow will be the flow recorded at the monitored inlet (ECHO-DTS-In), as well as any flow from subbasin 3. While the flow data recorded at

the inlet will not be perfectly representative, the data will provide a conservative estimate for the effectiveness of the flow control structure. The drainage area of subbasin 3 is 6% of the total drainage flowing into the DTS. Thus, the uncertainty associated with not including this subbasin in inflow measurements is expected to be proportionally low. If needed, the flow from subbasin 3 could be estimated using a mass balance approach using the outflow volume data. Additionally, while inputs from subbasin 3 could confound the analysis of any basic or enhanced treatment inadvertently provided by the DTS, the primary purpose of the DTS is flow control; therefore taking additional samples from subbasin 3 for a more representative analysis of treatment is not seen as an appropriate use of resources. Comparisons of parameter concentrations between the inlet (ECHO-DTS-In) and the outlet (ECHO-DTS-Out) will be qualified appropriately, because of this additional inlet to the DTS system.

Lastly, the inputs from the DTS outlet (ECHO-DTS-Out) will not represent all inputs to Echo Lake. The lake also receives direct runoff from the area immediately surrounding the lake (mostly residential), as well as inputs from subbasins 2 and 7. The inputs from these three areas are not represented in the samples collected from the DTS outlet, and any discussion of Echo Lake water quality in the final report will make this distinction.

## 5.5 Comparability

Comparability is a qualitative parameter expressing the confidence with which one data set can be compared with another. Comparability is addressed through use of standard techniques to collect and analyze representative samples, along with standardized data verification and reporting procedures described in this QAPP. Changes or updates to analytical methods and sampling techniques midway into the project must be tested, validated, and shown to be equivalent to existing methods. This validation must be approved by the project manager and QA officers before being implemented.

The overall purpose of this study is to provide regional stormwater permittees with useful information about the effectiveness of installed individual BMPs and combinations of stormwater BMPs. This project represents multiple, Ecology-approved stormwater treatment BMPs incorporated into an urban highway retrofit project. Although every retrofit project is unique due to site considerations, this project will gain transferable information in the form of 1) performance of common and relevant<sup>7</sup> individual treatment features installed under western Washington soil and climate conditions in an area of high impervious surface, and 2) the collective performance of these treatment features and a flow control structure on stormwater quality.

To ensure the findings of this study are relevant to BMP study needs in the region, the BMP designs and sample analysis should be comparable to those used in other jurisdictions. The methods and reporting limits used in this study are comparable to the 2011 TAPE protocol, with few exceptions. Sampling methods at the DTS follow TAPE sampling methods 1, 4 and

---

<sup>7</sup> The term relevant means the Filtreras® and bioretention planter boxes were designed to Ecology's specifications at the time (Ecology 2005).

5 (Ecology 2011, p.21); however, samples collected at the individual enhanced treatment features will be composite grabs due to physical limitations at the site. Additionally, the number of storm samples collected in this study is not likely to provide the statistical power achievable through the TAPE protocol. For the parameters required under the 2011 TAPE, the analytical methods in the current study will follow the acceptable methods for the 2011 TAPE. Reporting limits in the current study are lower or equal to those required by the 2011 TAPE, except dissolved zinc. In the previous stormwater sampling in this basin, dissolved zinc was always detected at least 18 times higher than the KCEL reporting limit targeted for this study. Therefore, influent non-detects are not expected for dissolved zinc during this project. All sample containers, preservation methods and holding times are comparable or more stringent than those required by the 2011 TAPE. Table 7 describes the DTS and individual treatment features evaluated in this study in terms of the 2012 SWMMWW (Ecology 2012).

**Table 7. Individual Enhanced Treatment or Flow Control Feature Description and Comparability**

Installation Type	Design Description	2012 SWMMWW Citation	Design Deviation
Bioretention Planter Box	Designed soil mix (40% cedar grove compost, 60% mineral aggregate, by volume), planted with trees, shrubs, and grasses within a vertical walled concrete and cement container. The planter boxes are completely impervious, and include an underdrain. Each feature treats between 0.05 and 0.13 acres.	BMP T7.30	No, follows 2005 and 2012 SWMMWW
Filtterra®	Proprietary soil mix planted with a single tree. Higher infiltration rates than bioretention and are underdrained. These are intended for phosphorus treatment. Each feature treats between 0.05 and 0.23 acres.	Section 12.5	No, follows GULD (Ecology 2015)
DTS	Detention tank with a system of eight foot diameter corrugated metal pipes, for a total length of 350 feet. The total capacity is 17,600 cubic feet. The tank is followed by a multiple orifice restrictor. This system is designed to handle all flow for the drainage basin (125 acres), but will provide flow control for 1.58 acres (total net new impervious surface).	Sections 3.2.2 and 3.2.4	TBD*

\*Determination of any design deviations of the DTS is currently underway. Results will be reported to the project leads and reported in the final report.

Some of the project objectives require comparison to historical data. Four aspects to consider for comparability are sampling method, analytical method, storm conditions sampled, and location. Table 8 summarizes the comparability for the three historical datasets to be used in this study. Green (dark) shading indicates good comparability, and yellow (light) shading indicates compare with caution. Overall, comparability between the datasets is good, but differences in methods and changes in location characteristics must be acknowledged in the final conclusions.

**Table 8. Historical Dataset Characteristics Compared to Proposed Sampling and Analysis for the Current Study.**

Historical Dataset	Sampling Methods	Analytical Methods	Storm Conditions	Location
SW Outfall (2010-2011)	Historical grab samples vs. flow-weighted autosamplers	Same methods, same laboratory	> 0.4 inches of rainfall on day of sampling, except one day of sampling with 0.08 inches	Subbasin 6 has been added to this drainage basin since sampling in 2010-2011. Previous data show subbasin 6 had stormwater quality similar to the outfall, but comparisons must be made with caution. Land use has changed over time.
Stormwater by Subbasins (2004)	Similar method of grab composites	Some differences in methods	> 0.15 inches of rainfall during sampling	Comparison should only be done for same drainage areas. Land use has changed for some subbasins.
Ambient Echo Lake Monitoring	On-going program	On-going program	n/a	Same location. Land use has changed over time.

## 5.6 Completeness

Completeness is defined as the total number of samples analyzed for which acceptable analytical data are generated, compared to the total number of samples submitted for analysis. Sampling according to storm criteria, along with adherence to standardized sampling and testing protocols outlined in this QAPP, will aid in providing a complete set of data for this project. The goal for completeness is a minimum of six storms sampled at each sampling location. The samples from each event should produce greater than 90% acceptable chemical and biological data under the QC conditions described in Section 8 of this QAPP.

Storms are unpredictable, and while preliminary flow monitoring and implementation of storm criteria increase the chances of collecting adequate sample volume, it is still possible that sampling will result in insufficient volume to perform all analyses. The target is 90% of samples with sufficient volume for the entire analyte list, including laboratory QC samples. This is 8.75 liters if PCB and/or toxicity analysis are needed; otherwise 5.0 liters is sufficient. If either the influent or effluent samples at a given installation are less than three liters, neither will be sufficient for laboratory analysis. If a sample pair does not have sufficient volume, samples from different installations with adequate volume will still be analyzed for that storm event. The flow chart in Figure 3 illustrates the decision tree for analysis of samples with insufficient volume, and Table 11 in Section 6.6.2 lists the parameters in order of priority. If completeness goals are not achieved, the project team will evaluate if the DQOs can still be met or if additional samples may be needed.

## 6.0 SAMPLING AND MONITORING PROCEDURES

---

Sample collection and monitoring procedures are presented here. The procedures for collecting samples from the individual stormwater treatment features and the DTS are discussed in Sections 6.1 and 6.2, respectively. The following sections also describe additional sampling considerations, equipment, sampling initiation, sample handling, decontamination procedures, collection of QA/QC samples, and preventative maintenance.

### 6.1 Sample Collection Procedures – Individual Enhanced Treatment Features

Composite grab samples will be collected at the inlet and outlet of four bioretention planter boxes and two Filterras<sup>®</sup> during each sampling event. Peristaltic pumps will be used to collect samples from the inlet and outlet of each bioretention planter box and Filterra<sup>®</sup>. New, pre-cleaned silicon tubing will be used for each sampling event, and Teflon<sup>®</sup> tubing will be pre-cleaned and site-dedicated. For bioretention planter boxes, sheet flow from the roadway enters a catch basin through a curb cut and can then pass through the inlet to the planter box. The catch basin is designed to remain full throughout the storm season; therefore, new stormwater entering the catch basin is expected to quickly spill into the planter box. Influent samples will be collected at the surface of the catch basin using peristaltic pumps, meaning samples will likely contain a mixture of new stormwater and water from previous storms that has been sitting in the catch basin<sup>8</sup>. During sample collection, the water level must remain at or near the inlet to the planter box in order to maintain effluent flow. There are no catch basins associated with the Filterra<sup>®</sup> inlets. To obtain influent samples at these locations, sheet flow must be concentrated using a partial physical barrier to the inlet. The exact strategy for sampling sheet flow will be determined on site and will be detailed in the final report. Potential methods are described in “*Sampling sheet flow*” in Ecology (2010), pages 15 and 16. The bioretention planter boxes and Filterra<sup>®</sup> effluent will be sampled from the underdrains, which can be accessed from overflows or clean outs (See Appendix A for details).

At each site, up to two-liter aliquots will be collected every 20 to 30 minutes and composited in glass (or Teflon<sup>®</sup>) carboys. Up to 8.75 liters<sup>9</sup> will be collected at each site over a period of at least two hours, until toxicity and PCB analysis goals are met (See Sections 6.1.1 and 6.6.1 for details). The end of the composite period will be considered the start of the holding time period for all samples.

---

<sup>8</sup> While these samples may not characterize fresh stormwater, they should be representative of the water entering the planter box; therefore, providing an appropriate comparison for the effluent samples.

<sup>9</sup> For each sampling event, an additional three liters will need to be collected from at least one site for PAH and NWTPH-Dx QC sample analysis (See Figure 3 for details).

Dissolved metals samples must be filtered within 15 minutes to meet holding time requirements. For each aliquot sample collected, a filtered aliquot will be collected into a 50-mL container, containing the preservative, using a peristaltic pump fitted with a 0.45 micron capsule filter. For each sampling event, a new capsule filter will be dedicated to one sampling location and replaced when clogged. The filtered aliquots will be composited once the field team has returned to the KCEL.

To ensure representative results, grab samples for NWTPH-Dx analysis will be sampled directly into a dedicated container at the beginning of the sample collection period. This avoids the splitting process, during which oils may be lost to equipment surfaces. This will result in one grab sample per storm at each site.

At the beginning of each sampling event, field parameters will be measured by collecting a volume of water in a pre-cleaned two-liter bucket using a peristaltic pump. An EXO YSI Sonde will be used to measure dissolved oxygen, temperature, pH and conductivity in the bucket. Turbidity will also be measured using a Hach 2100 Portable Turbidimeter.

### 6.1.1 Toxicity Tests Sample Collection

During four sampling events, an additional 3.79 L (1 gallon) will be collected for toxicity analysis at both the inlet and outlet of one bioretention planter box. The additional volume will be obtained as part of the composite sample collection process as described above in Section 6.1. The project manager and field team will have to communicate with the toxicology laboratory prior to sample collection to ensure organisms are available for the toxicity tests. If no toxicity is observed in the first two sampling events, the project team may agree to discontinue toxicity testing for the remaining storm events.

### 6.1.2 Summary of Sampling Strategy for Individual Enhanced Treatment Features

The following table (Table 9) summarizes the sampling strategy for the individual enhanced treatment features. This table does not include the field replicates that are described in Section 6.8.

**Table 9. Sampling strategy for the individual enhanced treatment features**

Parameter Group	Samples per Storm	Target Number of Storms	Max Number of Samples	Text Description
TSS, Nutrients, Metals, PAHs, and Bacteria	12	8	96	Composite sample at the inlet and outlet of four bioretention planter boxes and two Filterra <sup>®</sup> , one each per storm
PCBs	12	4	48	Composite sample at the inlet and outlet of four bioretention planter boxes and two Filterra <sup>®</sup> , one each per storm
NWTPH-Dx	12	8	96	Single grab sample per storm at the inlet and outlet of four bioretention planter boxes and two Filterra <sup>®</sup>

Parameter Group	Samples per Storm	Target Number of Storms	Max Number of Samples	Text Description
Toxicity	2	4	8	Composite sample at the inlet and outlet of four bioretention planter boxes and two Filterra <sup>®</sup> , one each per storm

## 6.2 Sample Collection Procedures – Detention Tank System

### 6.2.1 Flow Meter Installation and Analysis

An ISCO<sup>®</sup> 4230 air bubbler (level sensor-type flow meter) will be installed at both the inlet and outlet of the DTS, to record continuous flow prior to, and throughout, sampling for this project. Continuous flow recordings of storm events will be analyzed prior to sampling to determine residence time of the facility and gain a better understanding of how the DTS influences stormwater flow. Rainfall data from nearby King County rain gauges and flow data will provide information necessary to program the autosamplers based on forecasted rainfall.

Equipment installation (flow meters and autosamplers) includes, but is not limited to:

- Installing sample collection tubing in stormwater pipe
- Installing mounting rings for sampler tubing and flow meter probe
- Installing a suspension harness to hang sampler and flow meter in manhole
- Installing a liquid level actuator or telemetry equipment<sup>10</sup>
- Installing any other necessary sampler equipment into/onto sampler (bottles)

Installation and monitoring procedures will follow the flow monitoring Standard Operating Procedures (SOP), NPDES-CM-1000 (King County 2008)<sup>11</sup> and the instrument manual (Teledyne ISCO 1994); however, some site-specific adjustments/decisions have been made. The standard tygon bubble line tubing will be used, with the minimum length of tubing that can reach from the meter to the band in the pipe, with an extra one to four feet necessary to lift the meter to the surface for maintenance. The meter will be set at one bubble per second, but the rate will be adjusted if deemed necessary during preliminary monitoring. The 4230 model flow meter calculates flow using the Manning Equation, pipe diameter, material, and slope to convert the pipe water levels to flow. The inlet is a 30 inch corrugated metal stormdrain pipe (Manning roughness coefficient = 0.024) at a 1.35% slope and the outlet is a 36 inch non-metal acrylic pipe (Manning roughness coefficient = 0.009) at a 0.71% slope.

<sup>10</sup> This will be set to start sampling at a pre-determined flow and to stop sampling once flows have dropped below a set flow.

<sup>11</sup> Sections 2.1.1, 2.1.3, 2.2.1.4, 2.2.1.6, 2.2.1.7 and 3.4 refer to open channel flow monitoring and are not relevant to this project. The SOP refers directly to the air bubblers to be used at Echo Lake in Section 2.1.4.



During equipment installation, the flow meter will be programmed and tested. If flow is not available for a test run, a test run may be scheduled later to ensure the equipment is working properly. A preliminary assessment of flow data will consider the condition of the DTS and whether measurable leaks or unexpected inputs are entering the structure. During autosampler programming, field team members will have been trained to calibrate and program the equipment.

### 6.2.2 Flow-weighted Composite Sampling

Composite water samples will be collected using GLS ISCO® autosamplers equipped with 9.5-liter glass (or suitable fluorinated plastic) sample carboys. These carboys will be dedicated to either the DTS inlet or outlet for the duration of the project. Auto samplers will be installed inside access ports below street level using appropriate mounting hardware. The peristaltic pump in the autosamplers will be fitted with new and/or site-dedicated silicon tubing in the peristaltic pump for each sampling event. Site-dedicated Teflon® tubing and stainless steel fittings shall be used for all other tubing. All tubing, new and site-dedicated, will be decontaminated prior to use for this project.

The flow meters installed at each location will allow the collection of a flow-weighted composite sample. After a pre-determined volume of water passes by the flow meter, a pulse trigger is sent to the autosampler to collect a pre-determined sample aliquot ranging in volume from 100-mL to 500-mL. The aliquot volume is based on anticipated flow conditions predicted using previous flow and rainfall monitoring data.

Autosamplers will be programmed to collect flow-weighted samples for a 12 and 24 hour period<sup>12</sup>. The goal is to establish the autosampler setpoints to collect a total of seven liters<sup>13</sup> over at least 75% of the hydrograph, until PCB analysis goals are met. Once PCB analysis goals are met only five liters of water will be required (See Section 6.6.1 for more detail). An additional 0.25 liters will be collected at the outlet location for total and dissolved organic carbon (TOC/DOC) analysis. If the target volume is collected during a sampling event, sample volumes will follow the amounts recommended for each analysis in Section 6.6.2 (Table 11). The end of the composite period will be considered the start of the holding time period for all samples.

Autosamplers are not designed to collect samples for NWTPH-Dx nor bacteria analysis. Single grab samples for NWTPH-Dx analysis will be collected directly into a dedicated container. This avoids the splitting process, during which the oils may be lost to equipment surfaces. It is feasible to composite samples for bacteria analysis; however, the autosampler equipment is not sterile. Therefore, single grab samples will also be collected for bacteria analysis. When possible, these samples will be collected at the beginning of the sampling period. During eight storm events, the field team will be on site collecting samples

---

<sup>12</sup> The target sampling duration may be modified after initial flow monitoring.

<sup>13</sup> This goal differs from the target sample volume of 8.75 liters at the bioretention planter boxes because toxicity tests, which require 1.75 liters, will not be conducted at the DTS. For each sampling event, an additional three liters will need to be collected from at least one site (including enhanced treatment feature sites) for PAH and NWTPH-Dx QC sample analysis (See Figure 3 for details).

at the individual enhanced treatment features; therefore, field personnel will be available to collect bacteria and NWTPH-Dx grab samples from the DTS sites. During the remaining storms (up to six), the field team would not need to be on site during autosampler collection; therefore, collecting these samples may require an extra site visit.

At the beginning and end of each sampling event, field parameters will be measured by collecting water in a two-liter bucket hand lowered with a rope. An EXO YSI Sonde will be used to measure dissolved oxygen, temperature, pH and conductivity in the bucket. Turbidity will also be measured using a Hach 2100 Portable Turbidimeter.

Field personnel will retrieve the samples within 24 hours from the initiation of sampling. Once on site, flow data will be reviewed to assess whether stormwater runoff has subsided. If less than 24 hours have passed, stormflow is still present and the target volume has not been reached, sampling will continue. Sampling will be complete once the target volume has been reached, stormwater runoff has subsided<sup>14</sup>, or the sampler has sampled for 24 hours.

The following table (Table 10) summarizes the sampling strategy at the DTS.

**Table 10. Sampling strategy for the DTS**

Parameter Group	Samples per Storm	Target Number of Storms	Max Number of Samples	Text Description
TOC/DOC	1	12-14	14	One flow-weighted sample collected by autosampler per storm at the outlet only
TSS, Nutrients, Metals, and PAHs	2	12-14	28	Flow-weighted samples collected by autosampler at the inlet and outlet, one each per storm
PCBs	2	4	8	Flow-weighted samples collected by autosampler at the inlet and outlet, one each per storm
Bacteria, NWTPH-Dx	2	12-14	28	Single grab sample per storm at inlet and outlet

## 6.3 Sampling Initiation

### 6.3.1 Monitoring Forecast

Although it is ideal to randomize sampling days, this is unrealistic for the personnel resources. Alternatively, the project manager and field team will plan sampling events around the weather forecast and available personnel. When a qualifying storm is forecast (as defined in Section 5.2), field personnel will prepare for the upcoming event, after a discussion with the project manager. The forecast will be used to program the autosamplers based on the predicted rainfall amount.

<sup>14</sup> This will be based on evaluation of flow data collected prior to sampling and visual observation.

### 6.3.2 Sampling Initiation Procedures

Once the decision is made to initiate sampling, the field team will gather all materials for deployment, which may include decontaminated containers, batteries and ice, and proceed to sampling sites. When collecting or handling sample containers, field personnel will wear powder-free nitrile gloves for safe handling to prevent cross contamination of samples.

The field team will prepare autosamplers prior to the sampling event. This may include battery replacement, decontamination of autosampler tubing, placement of container(s) in the sampler, and programming each site's autosampler based on weather forecast information.

## 6.4 Sampling Considerations

Since this study deals with highway runoff, the field team will need to be vigilant of the roadway during sample collection and consider blocking the right-of-way with traffic cones to provide a more protected workspace. If traffic control is necessary for sample collection, one of the field team members will be FSU flagger-certified. Since the study area is adjacent to a Metro Park-and-Ride, the field team will contact Metro whenever equipment installation or sampling will occur, so that bus operators are aware of the activity associated with this project.

Sampling and flow meter installation at the DTS will require entering confined spaces. This will be done by King County personnel who have the training and experience to safely enter these spaces. King County confined space entry requirements and safety protocols will be followed at all times. Field personnel are confined space entry certified through the Wastewater Treatment Division (WTD) Permit-Required Confined Space Entry Program. All guidelines and requirements for confined space entry can be found in the WTD Permit-Required Confined Space Entry Program Manual (King County 1998).

## 6.5 Additional Sampling Equipment

Sampling and safety supplies include the following:

- Ziploc® bags
- Cooler with ice
- Nitrile gloves
- Field notebook
- Sample labels
- Chain-of-custody forms
- Camera
- Hard hats
- Safety vests

- Safety shoes
- Safety glasses
- Appropriate traffic control equipment

When visiting the sampling site, field personnel will record the following information on field forms that are maintained in a waterproof field notebook:

- Date and time of sample collection/visit
- Name(s) of sampling personnel
- Weather conditions
- Number and type of samples collected
- Instrument calibration procedures
- Field measurements
- Sequence of events (order of sites sampled)
- Time of flow data download
- Log of photographs taken<sup>15</sup>
- Comments on the working condition of the sampling equipment
- Deviations from sampling procedures
- Unusual conditions (e.g., water color or turbidity, presence of oil sheen, odors, and land disturbances)
- Signature of field project manager

## 6.6 Sample Handling Procedures

### 6.6.1 Qualifying Samples – Post-Sampling

Actual weather events will not always match the forecasted weather. As such, after sample collection but prior to sample analysis, it must be determined that the storm events meet criteria. For composite grab samples at the individual enhanced treatment features, if the target sample volume is reached for the paired inlet and outlet samples, then the criteria has been met. Figure 3 presents the decision tree for analysis of samples with insufficient volume.

These criteria are purposely non-restrictive, since storm conditions are indicated by the presence of sufficient effluent volume, which allows for a greater range of storms to be sampled.

---

<sup>15</sup> At a minimum, photos must document the autosampler and flow meter setup, one inlet and outlet at a bioretention planter box and Filterra<sup>®</sup> during sampling. Any deviations from the QAPP or unusual conditions must also be photographed.

Further analysis of storm conditions is necessary to identify whether samples collected at the DTS are representative of storm conditions. The project manager and field personnel will work together to analyze flow rate and rainfall data to determine hydrograph conditions during the sampled storm event. The storm sample is representative if the event meets the criteria listed in Section 5.2 and the hydrograph shows that 75% of the sample volume was collected during storm flows<sup>16</sup>. If these criteria are met, analysis will be based on sample volume as presented in Figure 3. The decision to analyze samples must be made within 24 hours of sample collection in order to comply with holding times.

---

<sup>16</sup> A storm flow threshold will be determined through preliminary flow monitoring, and will represent a flow rate indicative of storm conditions.

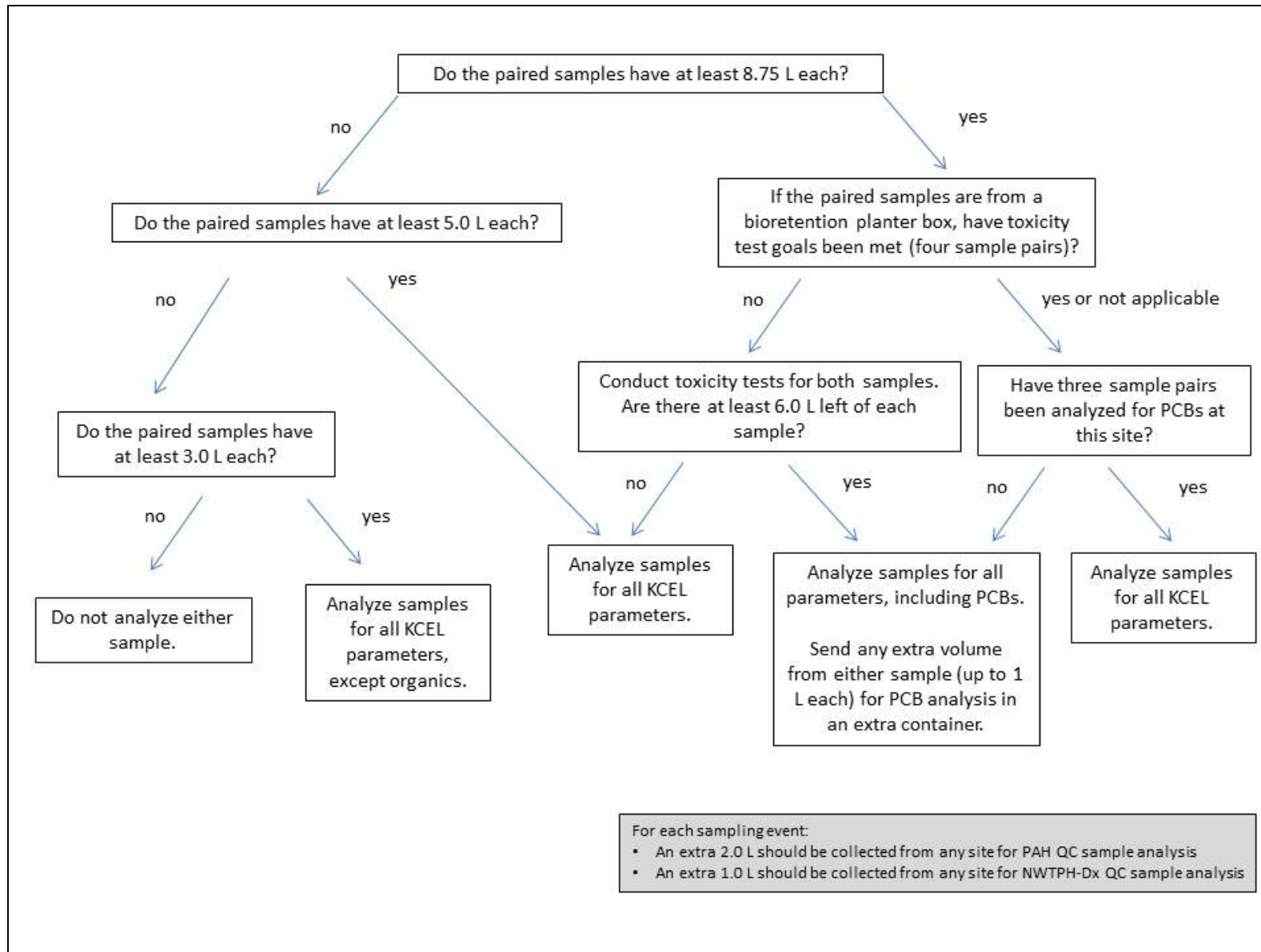

Figure 3. Sample Analysis Decision Tree Based On Paired Sample Volume

### 6.6.2 Sample Delivery and Storage

After sampling is completed, all samples (collected by grabs or autosamplers) will be stored on ice and transported back to KCEL. Each sample will then be split out into individual, analyte-specific laboratory containers, although some parameters (i.e., bacteria, NWTPH-Dx, and dissolved metals in grab samples) were already collected separately from the main composite. This will be done by continuously agitating the sample in the carboy while transferring sample aliquots to the appropriate laboratory containers using a pre-cleaned, site-dedicated Teflon® siphon tube. Only new, pre-cleaned silicon tubing will be used in this process. Each sample container will be filled to the appropriate level from the carboy. This procedure will ensure a representative sample from the carboy in each laboratory sample container.

Once the samples have been split, the orthophosphate phosphorus samples will be filtered using a 0.45 micron syringe filter. Dissolved metals samples collected by autosamplers will also be filtered using a cleaned Nalgene 500-mL filtration apparatus with 0.45 micron filters and a peristaltic pump. These samples will be filtered outside the 15-minute holding time requirements and the resulting data will be qualified with an “H” flag and a Data Anomaly Form (DAF) will be written explaining the “H” flag. Nitrate/nitrite samples will be filtered into the same container as the orthophosphate phosphorus samples, but with a pre-filtration holding time of one day, “H” flags should not be required.

Containers for PCB congener analysis will be delivered to Pacific Rim Laboratories within one to three months of sample collection. Samples will be held at KCEL at 4 degrees C in darkness until shipping. Samples will be maintained on ice and/or ice packs during the delivery process. Samples will either be driven to Pacific Rim Laboratories or shipped via overnight express delivery service.

Table 11 shows sample handling and storage requirements for all parameters, in order of priority.

**Table 11. Prioritized Parameter List with Sample Volume, Container, Preservation, Storage, and Holding Time Requirements**

Analyte(s)	Container	Storage Prior to Preservation	Preservation Holding Time	Preservation Technique	Analysis Holding Time
Total Metals and Hardness	Acid washed 500-mL HDPE	transport on ice	Add acid ≥24 hours before digestion	Ultra-pure HNO <sub>3</sub> to pH <2	180 days
Dissolved Metals	Acid washed 500-mL HDPE or PS filter unit	transport on ice	15 minutes for field filtration, add acid ≥24 hours before analysis	Ultra-pure HNO <sub>3</sub> to pH <2	180 days
Total Nitrogen	250-mL CWM HDPE	Cool to ≤6° C	2 days <sup>a</sup>	Freeze at -20° C	28 days
Total Phosphorus	Same container as Total Nitrogen	Cool to ≤6° C	2 days <sup>a</sup>	Freeze at -20° C	28 days
Nitrate + Nitrite	125-mL CWM HDPE	Cool to ≤6° C	1 day	Filter and freeze at -20° C	14 days
Orthophosphate Phosphorus	Same container as Nitrate + Nitrite	NA	15 minutes	Filter and freeze at -20° C	14 days
Ammonia-N	Same container as Nitrate + Nitrite	Cool to ≤6° C	1 day	Filter and freeze at -20° C	14 days
Fecal Coliform	Sterile 500-mL HDPE	Cool to ≤10° C	ASAP	Cool to ≤10° C <sup>b</sup>	24 hours
TSS	1-L CWM HDPE	Cool to ≤6° C	NA	Cool to ≤6° C	7 days
NWTPH-Dx	1-L ANM glass	Cool to ≤4° C	NA	Cool to ≤4° C or add HCl to pH < 2	7-14/40 days <sup>d</sup>
PAHs	1-L ANM glass	NA	15 minutes	Adjust pH to between 6 and 9, Cool to ≤6° C in the dark <sup>c</sup>	7/40 days <sup>e</sup>
TOC <sup>f</sup>	125-mL amber glass	Cool to ≤6° C	1 day	Add H <sub>3</sub> PO <sub>4</sub> to pH < 2, Cool to ≤6° C	28 days
DOC <sup>f</sup>	125-mL AWM HDPE	Cool to ≤6° C	1 day	Filter, H <sub>3</sub> PO <sub>4</sub> to pH <2, Cool to ≤6° C	28 days
PCB Congeners	2 1-L amber glass	Cool to ≤4° C	NA	Cool to ≤4° C in the dark	1 year
Toxicity Tests	1-gallon (3.79-L) plastic cubitainer	Cool to 0-6°C	NA	Store samples at 0-6°C in the dark with no headspace. (The preferred temperature is 4° C.)	36 hours to initiate <sup>g</sup>

<sup>a</sup> Samples and filtrates may be stored at ≤6° C if digested within 2 days of collection, otherwise they must be frozen. Holding time is then 28 days.

<sup>b</sup> Samples that contain chlorine must be treated with sodium thiosulfate or other appropriate treatment within 15 minutes of collection.

<sup>c</sup> Add a reducing agent (sodium thiosulfate) only if an oxidant (e.g., chlorine) is detected in the sample, and only necessary volume to remove detected oxidant.

<sup>d</sup> Seven days from sampling to extraction, 40 days from extraction to analysis.

<sup>d</sup> Seven days from sampling to extraction, unless preserved with HCl which results in a 14 day holding time; 40 days from extraction to analysis in either case.

<sup>f</sup> Only collected at the DTS outlet.

<sup>g</sup> Toxicity holding is 36 hours to initiate testing. Daily renewals for the 7-day chronic tests will be made using the same initial sample. All efforts will be made to initiate testing within 36 hours, experience with previous storm water projects has shown that some latitude in holding time may be necessary to obtain test organisms at the method required age (< 24 hours and within an 8 hour age range) and in sufficient numbers to initiate testing. The project manager will be informed of any delays in initiating tests.

HDPE – high density polyethylene; HNO<sub>3</sub> – nitric acid; PS – polystyrene; NA – not applicable; CWM – clear wide mouth; ANM – amber narrow mouth; AWM – amber wide mouth; H<sub>3</sub>PO<sub>4</sub> – phosphoric acid



### 6.6.3 Chain of Custody

Chain of custody (COC) will commence at the time that each autosampler is deployed or when grab sample collection begins. Autosamplers will be secured to ensure no tampering occurs. Thus, all samples will be under direct possession and control of King County field personnel. For COC purposes, closed/latched storm drains, autosamplers, and field vehicles will be considered “controlled areas.” All sample information will be recorded on a COC form, an example of which is included as Appendix B. This form will be completed in the field and will accompany all samples during transport and delivery to KCEL. Upon arrival at the KCEL, the samples will be split, preserved, and filtered as needed, then logged into the laboratory data management system and stored in a secure refrigerator. The date and time of sample delivery will be recorded and the COC form will be signed off in the appropriate sections at this time. Once completed, original COC forms will be archived in the project file.

Samples delivered after regular business hours will be split and preserved as needed and stored in a secure refrigerator until the next day. Samples delivered to the contract laboratory, Pacific Rim Laboratories, will be accompanied by a properly-completed KCEL COC form and custody seals will be placed on the shipping cooler. Pacific Rim Laboratories will be expected to provide a copy of the completed COC form as part of their analytical data package.

### 6.6.4 Sample Documentation

Sampling information and sample metadata will be documented using the methods described below:

- Field sheets generated by King County’s Laboratory Information Management System (LIMS) will be used at all stations and will include the following information:
  1. Sample ID number
  2. Locator/station name
  3. In-pipe station water depth at initiation and termination of sampling at the DTS sites
  4. Date and time of sample collection (start and end times of the compositing period)
  5. Initials of all sampling personnel
- LIMS-generated container labels will identify each container with a unique sample number, station and site names, collect date, analyses required, and preservation method.
- The field sheet will contain records of collection times, general weather, and the names of field crew.
- COC documentation will consist of the Lab’s standard COC form, which is used to track release and receipt of each sample from collection to arrival at the lab.

## 6.7 Decontamination Procedures

Once samples are collected, all re-usable equipment will be decontaminated. Autosampler containers and their associated Teflon® tubing shall be cleaned with: (1) Alconox® or other suitable laboratory detergent; (2) a sulfuric acid rinse; (3) a deionized water rinse; and (4) an acetone rinse. In a previous study, it was determined that acetone interferes with TOC and DOC analysis (King County 2014b); therefore, the equipment dedicated to the DTS and outlet will not be rinsed with acetone<sup>17</sup>.

All stainless steel fittings and connectors are to be cleaned in the same manner except they are not subject to the acid rinse step. Composite autosampler bottles and autosampler tubing will be cleaned prior to each sampling event according to laboratory standard operating procedures (KCEL SOP #234 and KCEL SOP #223) for collecting samples for low-level analysis using autosamplers. Acetone solvent rinses shall be used for carboys and tubing per Environmental Protection Agency (EPA) methods 1668C and 1613, except at the DTS sites. Proofed clean PCB sampling containers will be supplied by the contract laboratory. Proper personal protective equipment (new powder-free gloves for each site) should be worn during sampling activities and during decontamination processes. Bacteria sampling bottles are washed and autoclaved prior to sample collection.

## 6.8 Collection of QA/QC Samples

Table 12 summarizes the QA/QC samples to be collected to satisfy project objectives.

**Table 12. QA/QC Samples Required for Each Sampling Method Option**

QA/QC Sample Type	Number of QA/QC Samples	Collection Procedure
Equipment Blank	One for autosampler setup	Run ASTM Type I or II de-ionized water through autosampler equipment after decontamination and collect sample in the appropriate containers with preservative for a full analysis of all parameters collected during a sampled storm event. Place immediately on ice.
	One for peristaltic pump	Run ASTM Type I or II de-ionized water through peristaltic pump setup after decontamination and collect sample in the appropriate container for analysis of PCB congeners only <sup>a</sup> . Place immediately on ice.
Field Replicate	One at the inlet and outlet of at least one bioretention planter boxes and one Filterra® (4 total)	Collect replicate samples concurrently with primary field samples, following identical methods. Analyze for entire KCEL parameter list including NWTPH-Dx. One inlet and outlet sample pair will be analyzed for PCBs.
	One grab sample at the inlet and outlet of at DTS, bacteria and NWTPH-Dx only <sup>b</sup> (2 total)	Collect replicate grab samples concurrently with primary field samples, following identical methods. Analyze for bacteria and NWTPH-Dx only.

<sup>a</sup> Previous studies have indicated silicone tubing, used for peristaltic pumps, may be a source of PCBs.

<sup>b</sup> The manholes for the inlet and outlet points of the DTS do not have space for a second autosampler, making field replicates impossible.

<sup>17</sup> Although TOC and DOC will only be analyzed at the outlet of the detention tank system, the same decontamination process should be followed at both sites for better comparability.

## 6.9 Periodic Preventative Maintenance

Periodic preventative equipment maintenance will occur as needed between storm events to ensure equipment is operating properly. This will include changing batteries, changing the desiccant of the air pump, ensuring the unit is water tight, checking the bubbler line for wear and tear, and to check for debris that could interfere with readings. Signs of vandalism, rusting equipment, equipment failure, or other maintenance issues will be documented in field notebooks or on field data forms. Any significant changes in site conditions that will affect sampling will be documented in the final report under Deviations from the QAPP.

## 6.10 Additional Resources or References to Assist with this Section

National Oceanic and Atmospheric Administration (NOAA) Hourly Weather Graphs for Shoreline, WA available:

<http://forecast.weather.gov/MapClick.php?CityName=Shoreline&state=WA&site=SEW&textField1=47.7558&textField2=-122.34&e=0#.VLVo3 PTncs>

This site will be used to predict storms for sampling.

## 7.0 MEASUREMENT PROCEDURES

### 7.1 KCEL Analytical Methods and Detection Limits

Analytical methods are presented in this section, along with analyte-specific detection limit goals. For conventional analytes, nutrients, metals, PAHs and NWTPH-Dx, the terms MDL and RDL used in the following subsections refer to method detection limit and reporting detection limit, respectively. The KCEL reports both the LIMS reporting detection limit (LIMS RDL) and the LIMS method detection limit (LIMS MDL) for each sample and parameter, where applicable.

A practical quantitation limit (PQL) is generally defined as the minimum concentration of a chemical constituent that can be reliably quantified while the MDL is defined as the minimum concentration of a chemical constituent that can be detected. The LIMS RDL is analogous to the PQL for all analyses. It is verified either by including it on the calibration curve or by running a low level standard near the PQL value during the analytical run.

Actual LIMS MDLs and RDLs may differ from the target detection limit goals as a result of necessary analytical dilutions or a reduction of extracted sample amounts based on available sample volumes. When sample extracts are diluted because the concentrations for one or more target analytes exceeded the upper end of the calibration curve or parameter-specific interferences, MDLs and RDLs from the original, undiluted extract will be reported for parameters other than the target analytes that required dilution. Every effort will be made to meet the MDL/RDL goals listed in the QAPP; however, there may be times when the MDL/RDL values rise because the sample must be run at a greater dilution. This may be due to the concentration of some target analytes exceeding the calibration range, interfering target or non-target compounds, or run QC not passing (e.g., internal standard failures). Non-detected target analytes will be reported from the lowest dilution possible (no interferences and the run QC must pass). Target analytes that are detected must be reported from an appropriate dilution.

Tables 13 and 14 present methods and sensitivity for parameters analyzed in the field and in the laboratory, respectively. Organic parameter limits are based on nominal extraction volumes and concentration factors. Shortage of sample volume or excessive interferences may increase the limit goals presented in Table 14.

**Table 13. Method and Sensitivity for Parameters Analyzed in the Field**

Parameter	Method (SOP)	Sensitivity
Conductivity	KCEL SOP #206v2	15 µmhos/cm
Dissolved Oxygen	KCEL SOP #201v3	±0.2 mg/L
pH	KCEL SOP #202v3	±0.2 standard units
Temperature	KCEL SOP #203v3	±0.2 degrees Celsius
Turbidity	KCEL SOP #207v1	0.5 NTU

**Table 14. Method and Detection Limit Goals for Parameters Analyzed at the KCEL**

Parameter	Analytical Method	Method Detection Limit	Reporting Detection Limit
Dissolved organic carbon (detention tank outlet only)	SM5310B	0.5 mg/L	1 mg/L
Total organic carbon (detention tank outlet only)	SM5310B	0.5 mg/L	1 mg/L
Total suspended solids	SM2540D	0.5 mg/L	1.0 mg/L
Orthophosphate Phosphorus	SM4500-P-F	0.0005 mg/L	0.002 mg/L
Total phosphorus	SM4500-P-B, F	0.005 mg/L	0.01 mg/L
Total nitrogen	SM4500-N-C	0.05 mg/L	0.1 mg/L
Nitrate-nitrite Nitrogen	SM4500-NO3-F	0.01 mg/L	0.04 mg/L
Ammonia-N	Kerouel & Aminot 1997	0.002 mg/L	0.01 mg/L
Fecal coliform	SM9222D	1 cfu/100mL	1 min., 1E6 max cfu/100mL
Hardness as CaCO <sub>3</sub>	(EPA 200.7 or EPA 200.8) / SM2640B.ED19	200.7 = 0.25 200.8 = 0.331 mg CaCO <sub>3</sub> /L	200.7 = 1.24 200.8 = 0.331 mg CaCO <sub>3</sub> /L
Total cadmium	EPA 200.8	0.05 µg/L	0.25 µg/L
Dissolved cadmium	EPA 200.8	0.05 µg/L	0.25 µg/L
Total copper	EPA 200.8	0.4 µg/L	2.0 µg/L
Dissolved copper	EPA 200.8	0.4 µg/L	2.0 µg/L
Total lead	EPA 200.8	0.1 µg/L	0.5 µg/L
Dissolved lead	EPA 200.8	0.1 µg/L	0.5 µg/L
Total zinc	EPA 200.8	2.5 µg/L	2.5 µg/L
Dissolved zinc	EPA 200.8	0.5 µg/L	2.5 µg/L
PAHs	SW846-8270D SIM	0.01 to 0.02 µg/L	0.05 to 0.1 µg/L
Semi-Volatile Petroleum Products (NWTPH-Dx)	NWTPH-Dx (GC/FID) (Ecology 1997)	0.2 mg/L	0.2 mg/L

## 7.2 PCB Congener Analytical Methods and Detection Limits

PCB congeners will be analyzed following EPA Method 1668 Revision C (EPA 2010a), which is a high-resolution gas chromatography/high-resolution mass spectroscopy (HRGC/HRMS) method using an isotope dilution internal standard quantification. For this method, the MDL and RDL terms are less applicable because limits of quantitation are derived from calibration capabilities and ubiquitous, but typically low level, equipment and laboratory blank contamination. Additional reporting limit terms used particularly for PCB

congener analyses are sample specific detection limits and lowest method calibration limits. Sample specific detection limit (SDL) is determined by converting the area equivalent to 2.5 times the estimated chromatographic noise height to a concentration. For each sample analysis run, SDLs are determined individually for every congener and account for any effect of matrix on the detection system and recovery achieved through the analytical work-up. Lowest method calibration limits (LMCL), also called estimated quantitation limits (EQL), are based on calibration points from standard solutions. They are prorated by sample size and are supported by statistically-derived method reporting limit (MRL) values.

The PCB congener data will be reported to LMCLs and flagged down to the SDL value. In many cases the SDL may be below the LMCL. Method 1668C defines a Minimum Level (ML) value for each congener. The ML value is used to evaluate levels in the method blank. The ML is based on the LMCL and any laboratory performing the method should be able to achieve at least that level. Pacific Rim Laboratories uses an additional calibration point that is lower than the calibration points specified in the method; as such they are able to quantify congeners below the ML specified in the method.

Pacific Rim Laboratories will perform this analysis according to their SOP LAB02. A one-liter sample will be extracted followed by standard method clean-up, which includes an acid wash followed by Acid Silica and Alumina column chromatography. Analysis is performed with an SGE HT-8 column. Method 1668C requires that if a sample contains more than 1% total solids, the solids and liquid will be extracted and analyzed separately.

Table 15 lists the 209 PCB congeners and their respective target SDL and LMCL values. The reporting limits for individual samples may differ from those in Table 15 since they are determined by signal to noise ratios and changes to final volumes. Typical sample detection limits are shown. Note that several of the congeners co-elute and a single SDL or LMCL value is provided for the congeners in aggregate.

**Table 15. Detection Limits for PCB Congeners**

PCB(s)	MDL (pg/L)	LMCL (pg/L)	PCB(s)	MDL (pg/L)	LMCL (pg/L)	PCB(s)	MDL (pg/L)	LMCL (pg/L)
PCB-001	2.0	10	PCB-068	0.8	10	PCB-143	0.7	10
PCB-002	2.1	10	PCB-070	1.0	10	PCB-144	1.1	10
PCB-003	2.5	10	PCB-071	0.7	10	PCB-145	0.9	10
PCB-004	2.5	10	PCB-073	0.9	10	PCB-146	0.6	10
PCB-005/008	1.7	10	PCB-074	0.9	10	PCB-147	1.3	10
PCB-006	1.7	10	PCB-076	0.9	10	PCB-150	0.8	10
PCB-007	1.7	10	PCB-077	0.8	10	PCB-151	1.1	10
PCB-009	1.7	10	PCB-078	0.9	10	PCB-152	0.8	10
PCB-010	1.7	10	PCB-079	0.9	10	PCB-153	0.6	10
PCB-011	1.8	10	PCB-081	1.0	10	PCB-154	1.0	10

PCB(s)	MDL (pg/L)	LMCL (pg/L)	PCB(s)	MDL (pg/L)	LMCL (pg/L)	PCB(s)	MDL (pg/L)	LMCL (pg/L)
PCB-012/013	1.8	10	PCB-082	1.3	10	PCB-155	3.8	10
PCB-014	1.6	10	PCB-083/109	1.0	10	PCB-156	0.4	10
PCB-015	2.0	10	PCB-084	1.0	10	PCB-157	0.4	10
PCB-016	1.7	10	PCB-085	1.1	10	PCB-158	0.5	10
PCB-017	1.8	10	PCB-086/117	1.0	10	PCB-159	0.5	10
PCB-018	1.5	10	PCB-087/115	1.0	10	PCB-163/164	0.6	10
PCB-019	2.0	10	PCB-088	1.0	10	PCB-165	0.6	10
PCB-020/033	1.0	10	PCB-089	1.0	10	PCB-166	0.5	10
PCB-021	1.2	10	PCB-090	1.1	10	PCB-167	0.4	10
PCB-022	1.1	10	PCB-091/121	0.9	10	PCB-168	0.6	10
PCB-023	0.8	10	PCB-092	1.2	10	PCB-169	0.4	10
PCB-024	1.4	10	PCB-093/098/102	1.0	10	PCB-170	0.7	10
PCB-025	0.9	10	PCB-094	1.1	10	PCB-171	0.7	10
PCB-026	0.7	10	PCB-095	1.0	10	PCB-172	0.7	10
PCB-027	0.9	10	PCB-096	0.7	10	PCB-173	0.9	10
PCB-028	0.9	10	PCB-097/116	1.0	10	PCB-174	0.8	10
PCB-029	0.7	10	PCB-099	0.9	10	PCB-175	0.8	10
PCB-030	1.2	10	PCB-100	0.9	10	PCB-176	0.6	10
PCB-031	0.7	10	PCB-101	1.0	10	PCB-177	0.7	10
PCB-032	1.5	10	PCB-103	0.8	10	PCB-178	0.8	10
PCB-034	1.0	10	PCB-104	2.7	10	PCB-179	0.5	10
PCB-035	1.1	10	PCB-105/127	0.5	10	PCB-180	0.7	10
PCB-036	1.0	10	PCB-106	0.6	10	PCB-181	0.8	10
PCB-037	1.4	10	PCB-107/108	0.6	10	PCB-182/187	0.8	10
PCB-038	1.2	10	PCB-110	0.8	10	PCB-183	0.7	10
PCB-039	1.1	10	PCB-111	0.8	10	PCB-184	0.5	10
PCB-040/057	1.1	10	PCB-112/119	0.8	10	PCB-185	0.8	10
PCB-041	1.5	10	PCB-113	0.8	10	PCB-186	0.6	10
PCB-042	1.3	10	PCB-114	0.5	10	PCB-188	1.2	10
PCB-043/049	1.2	10	PCB-118	0.5	10	PCB-189	0.3	10
PCB-044	1.5	10	PCB-120	0.8	10	PCB-190	0.4	10

PCB(s)	MDL (pg/L)	LMCL (pg/L)	PCB(s)	MDL (pg/L)	LMCL (pg/L)	PCB(s)	MDL (pg/L)	LMCL (pg/L)
PCB-045	1.2	10	PCB-122	0.6	10	PCB-191	0.5	10
PCB-046	1.4	10	PCB-123	0.6	10	PCB-192	0.6	10
PCB-047/048	1.3	10	PCB-124	0.5	10	PCB-193	0.5	10
PCB-050	1.1	10	PCB-125	0.8	10	PCB-194	0.5	10
PCB-051	1.1	10	PCB-126	0.4	10	PCB-195	0.5	10
PCB-052/069	1.0	10	PCB-128/162	0.6	10	PCB-196	0.7	10
PCB-053	1.1	10	PCB-129	0.7	10	PCB-197	0.6	10
PCB-054	1.2	10	PCB-130	0.8	10	PCB-198	0.6	10
PCB-055/080	0.9	10	PCB-131	0.8	10	PCB-199	0.9	10
PCB-056	0.9	10	PCB-132/161	0.6	10	PCB-200	0.6	10
PCB-058	0.9	10	PCB-133	0.7	10	PCB-201	0.6	10
PCB-059	0.9	10	PCB-134	0.9	10	PCB-202	0.9	10
PCB-060	1.0	10	PCB-135	1.3	10	PCB-203	0.7	10
PCB-061	1.0	10	PCB-136/148	1.0	10	PCB-204	0.6	10
PCB-062	1.0	10	PCB-137	0.7	10	PCB-205	0.3	10
PCB-063	0.8	10	PCB-138/160	0.6	10	PCB-206	0.8	10
PCB-064/072	0.9	10	PCB-139/149	1.2	10	PCB-207	0.8	10
PCB-065/075	0.8	10	PCB-140	0.6	10	PCB-208	0.9	10
PCB-066	0.8	10	PCB-141	0.7	10	PCB-209	0.6	10
PCB-067	0.9	10	PCB-142	0.7	10			

### 7.3 Toxicity Test Procedures

Two sets of toxicity tests will be conducted. A 48-hour acute test with *Daphnia pulex* will be conducted according to KCEL SOP #412v2 and EPA Test Method 2021.0 (acute *Daphnia pulex*) and a 7-day chronic test with *Ceriodaphnia dubia* will be conducted according to KCEL SOP #408v3 and EPA Method 1002.0 (chronic *Ceriodaphnia dubia*).

For the acute test, each sample, including the control, is tested in four replicates. Each test chamber consists of a 30-mL beaker and contains 25 mL of control or treatment and five daphnid neonates. Additional water quality chambers are set up for each sample and the control for pH and dissolved oxygen measurements at 24 and 48 hours. Testing will consist of control and each inlet and outlet sample tested at 100% sample concentration, as a screening test. If either sample causes statistically significant mortality, as compared to the control, then a dilution series toxicity test will be performed on both samples. Replicates



are positioned randomly in a 9" x 13" glass tray according to random placement bench sheet generated by Comprehensive Environmental Toxicity Information System™ (CETIS) toxicity software and placed in the laboratory notebook.

For the chronic test, each sample, including the control, is tested in ten replicates. Each test chamber contains 15 mL of test solution or control (dilution) water and one *C. dubia* neonate. Individual broods are blocked across treatments, and each replicate contains a neonate from a different brood. Treatments are positioned randomly on the acrylic test board according to random placement bench sheet generated by CETIS and recorded in the laboratory notebook. Six additional blank replicates are placed at the center and four outer corners of the test board for temperature measurements. Testing will consist of control and each inlet and outlet sample tested at 100% sample concentration. If either sample causes statistically significant mortality and/or reproductive effects, as compared to the control, then a dilution series toxicity test will be performed on both samples.

## 8.0 QUALITY CONTROL

---

This section describes the laboratory QC required for this project. Field replicates and equipment blanks are described previously in Section 6.8. Details regarding the frequency and control limits of required QC samples are provided in Tables 16 through 22. Below are general descriptions of types of laboratory QC samples.

- Analysis of method blanks is used to evaluate the levels of contamination that might be associated with the processing and analysis of samples in the laboratory and introduce bias into the sample result. Method blank results for all target analytes (other than PCB congeners) should be “less than the MDL.”
- A laboratory duplicate is a second aliquot of a sample, processed concurrently and in an identical manner with the original sample. The laboratory duplicate is processed through the entire analytical procedure along with the original sample in the same quality control batch. Laboratory duplicate results are used to assess the precision of the analytical method and the relative percent difference (RPD) between the results should be within method-specified or performance-based quality control limits. In the case of PAHs, a matrix spike duplicate may be used in lieu of a laboratory duplicate due to the large number of non-detects frequently encountered in these analyses.
- A laboratory control sample is a sample of known analyte concentration(s) that is prepared in the lab from a separate source of analyte(s) relative to the calibration standards. Since the laboratory control sample analysis should follow the entire analytical process, it should be stored and prepared following the same procedures as a field sample. Analysis of a laboratory control sample is used as an indicator of method accuracy and long-term analytical precision.
- A spike blank is a spiked aliquot of clean reference matrix used for the method blank. The spiked aliquot is processed through the entire analytical procedure. Analysis of the spike blank is used as an indicator of method accuracy. It may be conducted in lieu of a laboratory control sample. A spike blank duplicate should be analyzed whenever there is insufficient sample volume to include a sample duplicate or matrix spike duplicate in the batch.
- A matrix spike is a sample aliquot fortified with a known concentration of a target analyte(s). The spiked sample is processed through the entire analytical procedure. Analysis of the matrix spike is used as an indicator of sample matrix effect on the recovery of target analyte(s).
- A matrix spike duplicate is a second sample aliquot fortified with a known concentration of a target analyte(s). The spiked sample is processed through the entire analytical procedure. Analysis of the matrix spike duplicate is used as an additional indicator of sample matrix effect on the recovery of target analyte(s) as well as an indicator of method precision.
- A surrogate is a known concentration of non-target analyte which is added to each sample (both analytical and QC samples) prior to extraction and analysis for all

trace organic analyses. Surrogate recovery is used as a sample-specific indication of method or matrix bias for target analytes. The surrogate is selected to behave in a similar manner to the target analytes.

- The ongoing precision and recovery (OPR) samples must show acceptable recoveries, according to the respective methods for data to be reported without qualification.

## 8.1 Field Measurements

Field measurement QC samples and associated control limits are summarized below. These samples will be analyzed at a frequency of once per sampling event.

**Table 16. Field Measurement QC Measurements and Control Limits**

Analyte	Duplicate (%RPD)	Replicate (%RPD)	Field Check Standard (% Recovery)	End Check (% Recovery)
Conductivity	10	10	90-110	90-110
Dissolved Oxygen	20	20	N/A	96 – 104*
Analyte	Duplicate Difference	Replicate Difference	Check Standard Difference	End Check Difference
pH	±0.2	±0.2	±0.2	±0.2
Temperature	±0.3° C	±0.3° C	N/A	N/A
Turbidity	20%	20%	±20% of the true value	±20% of the true value

\*Percent Saturation

## 8.2 Conventionals and Nutrients

Laboratory QC samples for conventional and nutrient analyses and associated control limits are summarized below. These QC samples will be analyzed at a frequency of one per analytical batch of 20 or fewer samples.

**Table 17. Conventional and Nutrient QC Samples and Control Limits**

Parameters	Method Blank	Lab Duplicate (%RPD)	Spike Blank (% Recovery)	Matrix Spike (% Recovery)	Lab Control Sample (% Recovery)
Total suspended solids	<MDL	25	NA	NA	80-120
Total organic carbon	<MDL	20	80-120	75-125	85-115
Dissolved organic carbon	<MDL	20	80-120	75-125	85-115
Ortho-phosphate	<MDL	20	80-120	75-125	85-115
Total phosphorus	<MDL	20	80-120	75-125	85-115
Total Nitrogen	<MDL	20	80-120	75-125	85-115
Nitrite/nitrate-N	<MDL	20	80-120	75-125	85-115
Ammonia-N	<MDL	20	80-120	75-125	85-115

## 8.3 Microbiology

Laboratory QC samples for bacteria will be analyzed at a frequency of one per analytical batch of 20 or fewer samples. If batches are less than 20 in size and received throughout the working day, then QC samples are run on samples received over a 4 hour period. Each QC batch will include a negative and positive control sample, a laboratory duplicate, and a before and after membrane filtration blank.

A negative control sample is media streaked with a non-target organism and analyzed through the complete procedure. The negative control is expected to show no detectable target organisms thereby evaluating the specificity of the method.

A positive control is a QC sample prepared or obtained by the lab which is known or expected to yield a positive response. A positive control can be either a sample of contaminated water or media streaked with the target organism, which is analyzed through the complete procedure.

A “before membrane filtration blank” is an aliquot of sterile diluent added to challenge the testing apparatus and conditions prior to membrane filtration of samples. The before filtration blank is analyzed to evaluate the sterility of the materials, equipment and work area at the beginning of sample analysis.

An after membrane filtration blank is an aliquot of sterile diluent added to challenge the testing apparatus and conditions after membrane filtration of samples. The after filtration blank is analyzed to evaluate cross-contamination during sample analysis.

## 8.4 Metals

Laboratory QC samples for trace metals analyses and associated control limits are summarized below. These QC samples will be analyzed at a frequency of one per analytical batch of 20 or fewer samples.

**Table 18. Metals QC Samples and Control Limits**

Parameters	Method Blank	Lab Duplicate (%RPD)	Matrix Spike (% Recovery)	Spike Blank (% Recovery)
Total metals, dissolved metals and hardness	<MDL	20	75-125	85-115

## 8.5 Organic Compounds - KCEL

Laboratory QC samples for organic compounds analyzed by KCEL and their associated control limits are summarized below. Control limits are empirically derived and may change annually; therefore, control limits reported with data may or may not match the

limits below. Unless otherwise noted, these QC samples will be analyzed at a frequency of one per analytical batch of 20 or fewer samples.

**Table 19. NWTPH-Dx QC Samples and Control Limits**

Parameters	Method Blank	Spike Blank (% Recovery)	Matrix Spike (% Recovery)	MS/MSD (%RPD)	Lab Duplicate (%RPD) <sup>a</sup>	Surrogate (% Recovery)
Semi-Volatile Petroleum Products (NWTPH-Dx)	<MDL	50-150%	NA	NA	40	50-150

<sup>a</sup> If there is insufficient volume for a lab duplicate, a spike blank duplicate will be prepared for precision evaluation.

**Table 20. Individual PAH Matrix Spike Recovery Limits**

Analyte	Lower QC Limit (%)	Upper QC Limit (%)	%RPD
1-Methylnaphthalene	41	94	40
2-Methylnaphthalene	41	94	40
Acenaphthene	45	101	40
Acenaphthylene	45	98	40
Anthracene	49	103	40
Benzo(a)anthracene	62	112	40
Benzo(a)pyrene	66	108	40
Benzo(b,j,k)fluoranthene	48	118	40
Benzo(g,h,i)perylene	59	109	40
Chrysene	52	110	40
Dibenzo(a,h)anthracene	60	107	40
Fluoranthene	48	131	40
Fluorene	34	128	40
Indeno(1,2,3-cd)Pyrene	60	109	40
Naphthalene	43	77	40
Phenanthrene	59	93	40
Pyrene	47	123	40

If there is insufficient sample volume for a matrix spike duplicate, a spike blank duplicate will be prepared.

**Table 21. Individual PAH Spike Blank Recovery Limits**

Analyte	Lower QC Limit (%)	Upper QC Limit (%)	%RPD
1-Methylnaphthalene	46	97	40
2-Methylnaphthalene	46	97	40
Acenaphthene	50	100	40
Acenaphthylene	51	107	40
Anthracene	50	116	40
Benzo(a)anthracene	55	122	40
Benzo(a)pyrene	59	125	40
Benzo(b,j,k)fluoranthene	52	120	40
Benzo(g,h,i)perylene	59	116	40
Chrysene	48	127	40
Dibenzo(a,h)anthracene	57	122	40
Fluoranthene	54	131	40
Fluorene	54	117	40
Indeno(1,2,3-cd)Pyrene	59	120	40
Naphthalene	39	94	40
Phenanthrene	55	104	40
Pyrene	52	123	40

**Table 22. Laboratory QC Limits for PAH Surrogate Recoveries**

Parameter	Lower QC Limit (%)	Upper QC Limit (%)
2-Fluorobiphenyl	31	101
d14-Terphenyl	51	130

## 8.6 PCB Congeners

The PCB congener method provides reliable analyte identification and very low detection limits. An extensive suite of labelled surrogate standards (Table 23) is added before samples are extracted. Data are “recovery-corrected” for losses in extraction and clean-up, and analytes are quantified against their labeled analogues.

**Table 23. Labeled Surrogates and Recovery Standards Used for EPA Method 1668C PCB Congener Analysis**

<sup>13</sup> C-labeled PCB Congener Surrogate Standards				
1	37	123	155	202
3	54	118	167	205
4	81	114	156	208
15	77	105	157	206
19	104	126	169	209
			189	
<sup>13</sup> C-labeled Cleanup Standards				
28	111	178		
<sup>13</sup> C-labeled Internal (Recovery) Standards				
9	52	101	138	194

QA/QC samples include method blank, OPR sample, and surrogate spikes. Method blanks and OPR, which are the same as spike blanks, are each included with each batch of samples. Surrogate spikes are labeled compounds that are included with each sample. The sample results are corrected for the recoveries associated with these surrogate spikes as part of the isotope dilution method. In addition, a laboratory duplicate will be conducted with each batch of samples. Note that a matrix spike and matrix spike duplicate are not required, nor meaningful under Method 1668C. Method 1668C has specific requirements for method blanks that must be met before sample data can be reported (see Section 9.5.2 of Method 1668C). The OPR samples must show acceptable recoveries, according to Method 1668C, to analyze the samples and report the data. A summary of the quality control samples are shown in Table 24.

**Table 24. PCBs QA/QC Frequency and Acceptance Criteria**

	Method Blank	Lab Duplicate (RPD)	OPR (% Recovery)	Surrogate Spikes
<b>Frequency</b>	<b>1 per batch</b>	<b>1 per batch</b>	<b>1 per batch</b>	<b>Each sample</b>
PCB Congeners	<LMCL <sup>a</sup>	RPD <50%	laboratory QC limits <sup>b</sup>	laboratory QC limits <sup>b</sup>

batch = 20 samples or less prepared as a set

<sup>a</sup> EPA Method 1668C blank criteria (see Table 2 of the published method) is to be below the Minimum Levels: 2, 10, 50 pg/congener depending on the congener with the sum of all congeners below 300 pg/sample. Higher levels are acceptable when sample concentrations exceed 10x the blank levels.

<sup>b</sup> EPA Method 1668C OPR recovery criteria 60-135% for select congeners (see Table 6 of the published method) will be used as quality control limits.

## 8.7 Corrective Action for QC Problems

Corrective action for field measurements and laboratory analysis will follow those described in each SOP. Examples of corrective action include:

- Re-analyzing the samples
- Re-extracting the samples
- Re-preparing of the calibration verification standard for laboratory analyses
- Re-calibrating the field equipment
- Qualifying results as described in Section 9.2

## 8.8 Toxicity Tests

The following sections describe the test acceptance and test condition requirements for both the acute and chronic toxicity tests.

### 8.8.1 *Daphnia pulex* Acute Toxicity Test

The criterion for test acceptance is 90% or greater survival in control animals. Specific test conditions per EPA Test Method 2021.0 include:

- Test type: Static non-renewal
- Test duration: 48 hours
- Temperature: 20°C ±1°C
- Light quality: Ambient laboratory illumination
- Light intensity: 10-20 µE/m<sup>2</sup>/s (50-100 ft-c)
- Photoperiod: 16 hours light, 8 hours darkness
- Test chamber size: 30 mL
- Test solution volume: 25 mL
- Age of test organisms: Less than 24-hours old
- Number of organisms per replicate: 5
- Number of replicate chambers per concentration: 4
- Number of organisms per concentration: 20
- Feeding regime: Feed yeast trout chow (YTC) and *Selenastrum* while holding prior to the test
- Dilution water: Uncontaminated well water
- Test concentrations: 100% and a control
- Endpoint: Mortality
- Test acceptability criterion: 90% or greater survival in controls



### 8.8.2 *Ceriodaphnia dubia* Chronic Toxicity Test

The criterion for test acceptance is 80% or greater control survival and average of 15 or more young per surviving female in the control. Specific test conditions per EPA Method 1002.0 include:

- Test type: Static renewal (required)
- Temperature (EC):  $25 \pm 1$ EC
- Light quality: Ambient laboratory illumination (recommended)
- Light intensity: 10-20  $\mu\text{E}/\text{m}^2/\text{s}$ , or 50-100 ft-c (ambient laboratory levels)
- Photoperiod: 16 hours light, 8 hours dark
- Test chamber size: 30 mL
- Test solution volume: 15 mL
- Renewal of test solutions: Daily
- Age of test organisms: Less than 24 hours; and all released within a 8-hour period
- Number of neonates per test chamber: 1, assign using blocking by known parentage
- Number of replicate test chambers per concentration: 10
- Number of neonates per test concentration: 10
- Feeding regime: Feed 0.1 mL each of YTC and algal suspension daily
- Aeration: None (recommended)
- Dilution water: Uncontaminated source of natural water,
- Test concentrations: 100% and a control
- Test duration: Until 60% or more of surviving control females have three broods (maximum test duration 8 days)
- Endpoints: Survival and reproduction
- Test acceptability criteria: 80% survival, average of 15 or more young per surviving female in the control.
- Reference Toxicant Testing: Monthly, control limits mean  $\text{IC}_{25} \pm 2\text{SD}$ .

## 8.9 Flow Data

Water level at both locations will be hand measured at least five times throughout the project and compared with the readings from the flow meter. The meter will be recalibrated as necessary, and the RPD between the recorded water levels should be within 10% or the generated flow data will be qualified according to Section 9.2.2. Results will be documented in the field sheets.

A second flow meter will be installed at the downstream end of the outlet from the DTS (through downstream catch basin from ECHO-DTS-Out) to generate replicate flow data for three two-week periods during the project. Data qualification is described in Section 9.2.2.

The Manning Equation is only to be used to calculate gravity flow; therefore, if the pipe fills, flow cannot be calculated accurately due to pressure influences. The data will be reviewed to verify the water level remained below the full diameter of the pipe. If the water level exceeds the diameter of the pipe, the project team will explore alternative methods of monitoring flow.

## 8.10 Audits

Audits can help verify data quality by ensuring the QAPP is implemented correctly, and the quality of data is acceptable. To verify samples are collected according to the methods described in the QAPP, the project manager will conduct a field audit by supervising at least one sampling event for this project. Documentation will include field notes and pictures taken by the project manager. The project manager will also conduct an analytical audit by a preliminary data review; comparing analytical results, including detection limits, to the QAPP-specified goals. If review of chemistry data suggests sampling or method revisions are required, outside of those allowed in the cited methods and SOPs, an addendum to this QAPP will be prepared.

## 9.0 DATA MANAGEMENT, VERIFICATION, AND REPORTING

---

This section explains the standard practices for managing, verifying and reporting data collected or analyzed as part of this study.

### 9.1 Data Storage

Data will not be distributed outside each lab unit or to clients until it has met the full definition of final data. “Final Data” is defined as approved data posted to the historical database (EDS) or is otherwise in its final reportable and stored format (if not a LIMS parameter). This implies the data has been appropriately peer reviewed, properly qualified and is in its final format in terms of units and significant figures.

King County will retain records of all monitoring information, including all calibration and maintenance records and all original recordings for continuous monitoring instrumentation, copies of all reports generated for this study, and records of all data used in this study, for a period of at least five years.

### 9.2 Data Verification and Validation

#### 9.2.1 Analytical Data

Data reported by the KCEL, including field measurements, must pass a review process before final results are available to the client. A “Peer Review” process is when a second analyst or individual proficient at the method reviews the data set. The reviewer will complete a data review checklist which will document the completeness of the data package and if any QC failures exist. In addition to the peer review, the data will be reviewed by the technical coordinator (TC) within each lab unit or the LPM for adherence to project goals. Results of these reviews will be documented in data review checklists, DAFs, and the QA narrative.

Once data review is complete and all data quality issues have been resolved, the data in LIMS will be moved to the LIMS historical database. Signatures or initials of the reviewer(s) indicate formal approval of hardcopy data typically on the review checklist. A copy of this approved checklist should be stored with the final hardcopy laboratory data package.

For data generated by KCEL, a QA narrative will be generated by the LPM and will summarize all QA/QC results for analytical data generated by the KCEL. This narrative will also include Field Observation Forms generated by field personnel describing sample collection conditions and anomalies. An EPA Level 2A data validation will be conducted by

the project manager in accordance to the National Functional Guidelines (EPA 2010b and EPA 2014).

All necessary data needed for independent review of PCB congener data will be provided by Pacific Rim Laboratories. A subcontracted data validator will review the PCB congener data following EPA Level III guidelines (EPA 1995). Both data validation sets will be based on QA/QC samples and included in the final report as an appendix.

Qualifiers will be applied to analytical data during the data quality review process, and are presented in Table 25 (KCEL) and Table 26 (Pacific Rim Laboratory).

**Table 25. KCEL and EIM Equivalent Data Qualifiers**

KCEL Qualifier	Description	EIM Qualifier
<b>General</b>		
H	Indicates that an analysis holding time criterion was not met.	J
SH	Indicates that a sample handling criterion was not met. The sample may have been compromised during the sampling procedure or may not comply with storage conditions or preservation requirements.	J
R	Indicates that the data are judged unusable by the data reviewer. The qualifier is applied based on the professional judgment of the data reviewer rather than any specific set of QC parameters and is applied when the reviewer feels that the data may not or will not provide any useful information to the data user.	Reported as an observation
<MDL	Applied when a target analyte is not detected or detected at a concentration less than the associated method detection limit (MDL). The MDL is the lowest concentration at which a sample result will be reported.	U
<RDL	Applied when a target analyte is detected at a concentration greater than or equal to the associated MDL but less than the associated reporting detection limit (RDL). RDL is defined as the lowest concentration at which an analyte can reliably be quantified.	JT
RDL	Applied when a target analyte is detected at a concentration that, in the raw data is equal to the RDL.	No qualifier added
TA	Applied to a sample result when additional narrative information is available in the text field. The additional information may help to qualify the sample result but is not necessarily covered by any other qualifier.	C

KCEL Qualifier	Description	EIM Qualifier
<b>Chemistry</b>		
B, B2 or B3	Applied to a sample result when an analyte was detected at a concentration greater than the MDL in the associated method blank. The qualifier is applied when the sample concentration is >MDL but less than five or ten times the blank concentration. The qualifier indicates that the analyte concentration in the sample may be significantly influenced by laboratory contamination.	B, B2 = UJ B3 = JL
E	Applied to a sample result that was measured at a concentration greater than the calibration range of the method. It is applied when the detected analyte concentration exceeds the upper instrument calibration limit and further dilution is not feasible. The reported value is an estimated analyte concentration.	E
J	Applied to a sample result that is considered an estimated value.	J for lab data; EST for field measurements
JG	Applied to a sample result that is considered an estimated value with a low bias. This will typically be applied when QC results indicate the recovery of the analyte is below the expected limits of the method.	JG
JL	Applied to a sample result that is considered an estimated value with a high bias. This will typically be applied when QC results indicate the recovery of the analyte is above the expected limits of the method.	JL
<b>Microbiology</b>		
FAIL	The result of the positive or negative control failed (applied to QC results only)	No qualifier added
PASS	The result of the positive or negative control passed (applied to QC results only)	No qualifier added
C	Value is an estimate, based on presence of confluent growth	J
TNTC	Too Numerous To Count: Used when the number of target colonies exceeds the countable range and no reliable estimate is available.	Reported as an observation

**Table 26. Pacific Rim Laboratory Data Qualifiers**

Qualifier	Description	EIM Qualifier
U	Indicates the compound was not detected at the concentration listed.	U
J	Indicates the sample concentration is less than the lowest point on the calibration curve.	J

Qualifier	Description	EIM Qualifier
N	Indicates the compound was not detected due to incorrect ion ratio. The concentration is reported as the estimated maximum possible concentration (EMPC)	U, with description in Comment Field
B	Indicates the compound was detected in the associated method blank.	Depends on data validation (UJ, JL, or Null)
B1	Indicates the sample concentration is less than five times the concentration found in the method blank.	UJ

Additionally, equipment blank and field replicate results will be presented in the final report. If these results indicate a problem with precision or accuracy, data qualifiers may be applied based on the National Functional Guidelines (EPA 2010b and EPA 2014) and best professional judgment.

### 9.2.2 Flow Data

Flow measurement devices and methods will be consistent with accepted scientific practices and will be selected and used to ensure the accuracy and reliability of measurements of the volume of monitored discharges. The devices will be installed, calibrated, and maintained to ensure that the accuracy of the measurement is consistent with the accepted industry standard for that type of device. The device will be recalibrated in conformance with manufacturer's recommendations or at a minimum frequency of at least one calibration per month for the duration of the project. Calibration records will be maintained for a minimum of three years beyond the final report. Additionally, the ISCO 4230 Flow Meters have a built in compensation for instrument drift, which is detailed in the manual.

Flow data collected in association with this monitoring program will be reviewed for quality assurance purposes. These data will be examined for gaps, anomalies, or inconsistencies between the water level and precipitation data. In the event that quality assurance issues are identified on the basis of these reviews, a site visit will be performed immediately to troubleshoot the problem and to implement corrective actions if possible.

During verification of the water level readings, if the relative percent difference (RPD) between the water level measurements is greater than 10%, all flow data generated since the previous calibration will be "J" flagged and considered estimated. If the difference is such that the generated flow data is deemed unusable, the project team will "R" flag and reject the data. Additionally, if the RPD is greater than 20% between flow data generated by the original meter and the secondary meter at the DTS outlet (ECHO-DTS-Out), the data collected since the last replicate flow measurements will be "J" flagged and considered estimated. If the flow data is deemed unacceptable, the data will be "R" flagged and rejected. The field team will troubleshoot on site to determine what corrective actions may be appropriate. Flow data generated from water levels that are within an inch of the top of

the pipe will be “R” flagged and rejected, as the Manning Equation is not to be used to calculate flow for a full pipe. If flow data is rejected over a sampling period, the project team may decide not to analyze samples collected by autosamplers.

### 9.2.3 Rain Gauge Data

Rainfall data is available on the King County Hydrological Information Center (HIC) website (<http://green2.kingcounty.gov/hydrology/>). Rainfall from two gauges (04U, 35U) near the study site will be used to evaluate relative storm intensity for sampling events. Rainfall is measured by a tipping bucket rain gauge recording rainfall in 0.01 inch increments. The time of each 0.01 inch tip is recorded by a data logger and transmitted to the King County hydrologic database hourly. The database generates a report of seven days of 24 hour rainfall totals for all reporting rain gauges. Designated staff examine the report daily to verify gauge function and data reasonableness. Routine site visits are made to clean and maintain the equipment and test the calibration of the rain gauge according to manufacturer’s specifications. Periods of missing record are filled with data from a nearby gauge and flagged “E”. Data for periods when the gauge is more than 10% out of calibration may be adjusted. Data logger time is checked daily by the telemetry program and adjusted if off by more than five seconds.

Rainfall data that are entered into the hydrologic database are initially flagged “P” for provisional. Final QA/QC is performed at least annually. Field notes are checked to verify rain gauge calibration. Daily rainfall totals are compared to three or four nearby sites by charting cumulative totals and visually looking for anomalies. Tabular daily totals are examined and 15-minute totals for the comparison sites are put in columns in a spreadsheet. A visual check is performed to search for periods where a funnel may be plugged or otherwise malfunctioning, indicated by rainfall records being too regularly spaced or exhibiting unnatural intensity compared to nearby sites. These QC procedures are used whenever the ongoing examination of the daily reports indicates a problem with a gauge. Rainfall data that has passed final QC is flagged “L” for Locked, meaning it cannot be overwritten without special administrator permission.

## 9.3 Data Reduction, Review, and Reporting

All lab and field measurements will follow the procedures outlined in the KCEL’s SOPs and QA Manual. Laboratory personnel will be responsible for internal quality control verification, proper data transfer, and reporting data to the project manager via LIMS.

The ambient water quality data for Echo Lake will be collected in a separate effort, but will be subject to the same quality control verification as the data generated for this project. These results will be summarized and analyzed in a technical memorandum under this project.

### **The Echo Lake Historical Data technical memo will include:**

- Peer-reviewed analysis of historical water quality data in Echo Lake

- A section discussing QA/QC for the data
- An appendix including all raw analytical data with laboratory qualifiers (described in Section 9.2)

**The final report of this study will include:**

- A summary of parameter concentrations at the inlet and outlet at each sampled treatment feature
- A summary of flows during sampled storm events at the detention tank system
- A discussion of treatment effectiveness based on data analysis
- A section discussing QA/QC for the data
- An appendix including all raw analytical data with laboratory qualifiers (described in Section 9.2)
- An appendix including bench sheets for toxicity tests
- A toxicity data analytical report
- Comprehensive Environmental Toxicity Information System™ (CETIS) export files for the toxicity tests
- Final data will be entered into the EIM system by the close of the project
- Ecology and the City of Shoreline representatives will provide a technical review of the final report



## 10.0 DATA QUALITY ASSESSMENT AND DATA ANALYSIS

---

After data verification and validation, the project manager will conduct a data quality assessment to ensure the data satisfies the MQOs and is of sufficient quality to meet study goals. The following list outlines the steps in this process, as described in the Data Quality Assessment Guidelines (EPA 2006):

1. Review the project's objectives and sampling design.

The first step in this process is to verify whether the execution of the sampling design satisfies the project objectives. Deviations from the QAPP and site condition anomalies will be considered as part of this step.

2. Conduct a preliminary data review.

By reviewing the QA reports and data validation memos, the project manager can assess whether the goals of precision, bias, sensitivity, accuracy, representativeness, comparability and completeness have been achieved, as defined in Sections 4 and 5 of this QAPP. The project manager will then explore the data by generating summary statistics and basic graphs. Any observed anomalies will be investigated. The LIMS MDL value (sample-specific) will be used as a surrogate for any non-detect results. In general, this results in a high bias, which will be addressed as appropriate in the final report.

3. Select the statistical method.

A rank sum test will be used for comparison between inlet and outlet results, with a Wilcoxon signed-rank test for the individual enhanced treatment features, as recommended by Ecology (2011). Since the individual features are expected to reduce contaminant concentrations, a one-tailed test may be appropriate; however, if the preliminary data review suggests a possible increase in contaminant concentration, a two-tailed test will be used. Two-tailed tests may also be used for comparing the new dataset to historical stormwater quality data. The project manager may decide not to include statistical analysis for parameters with low frequency of detection, due to increased uncertainty.

If results are similar across a given treatment type, they may be pooled by storm event for statistical analysis, in order to increase statistical power. This will be based on best professional judgement, but any conclusions will be qualified, acknowledging these are not true replicates, despite comparable design and stormwater input.

The long-term dataset of Echo Lake water quality will be assessed for trends relating to the installation of stormwater treatment features in the drainage basin. Statistical tests could include Seasonal Kendall Tests or Wilcoxon-Mann-Whitney

Step Trend tests. A King County limnologist will be consulted during this process to help with appropriate data interpretation given known lake processes.

4. Verify the assumptions of the statistical method.

The distribution of the datasets will determine whether parametric or non-parametric statistical tests will be implemented. The number of samples proposed for this project is not based on a power analysis, but instead on the maximum number of samples that can feasibly be collected by the field personnel. If variability is high within the dataset, it may result in low statistical power, meaning lower probability of detecting differences between the populations (e.g., inlet vs. outlet sample results).

5. Draw conclusions from the data.

In this step, the statistical tests will be conducted and the uncertainty of the results will also be assessed. In the final report, visual representations of the data may include scatter plots, box plots or bar charts with error bars representing standard deviations or confidence intervals. The report will also include descriptions and detailed interpretations of the statistical results. Suggested amendments to the sampling design for future use will also be discussed.

## 11.0 REFERENCES

---

- APHA 1998. Standard Methods for the Examination of Water and Wastewater, 20th Edition. American Public Health Association. Washington, D.C.
- Ecology. 1997. Analytical Methods for Petroleum Hydrocarbons. Publication No. ECY 97-602.
- Ecology. 2005. Stormwater Management Manual for Western Washington (SWMMWW). Publication No. 05-10-33.
- Ecology. 2010. How to do stormwater sampling: a guide for industrial facilities. Publication No. 02-10-071.
- Ecology. 2011. Guidance for Evaluating Emerging Stormwater Treatment Technologies. Technology Assessment Protocol – Ecology. Publication No. 11-10-061.
- Ecology. 2012. Stormwater Management Manual for Western Washington (SWMMWW) as Amended in December 2014. Publication No. 14-10-055.
- Ecology. 2015. General Use Level Designation for basic (TSS), enhanced, phosphorus and oil treatment for Americast Filterra®. March 2015.  
<[http://www.ecy.wa.gov/programs/wq/stormwater/newtech/use\\_designations/FILTERRAguld.pdf](http://www.ecy.wa.gov/programs/wq/stormwater/newtech/use_designations/FILTERRAguld.pdf)>.
- EPA. 1995. EPA Region 10 SOP For the Validation of Method 1668 Toxic, Dioxin-like, PCB Data. Revision 1, December 8, 1995. Prepared by EPA Region 10 Environmental Services Division, Seattle, WA 98101.
- EPA. 1999. Preliminary data summary of urban stormwater best management practices. United States Environmental Protection Agency, Office of Water, Washington DC. EPA-821-R-99-012.
- EPA. 2006. Data Quality Assessment: A Reviewer’s Guide. U.S. Environmental Protection Agency, Office of Environmental Information, Washington DC. EPA-240-B-06-002.
- EPA. 2010a. Method 1668C, Chlorinated biphenyl congeners in water, soil, sediment biosolids, and tissue by HRGC/HRMS. U.S. Environmental Protection Agency, Office of Water, Office Science and Technology, Washington, D.C. EPA-820-R-10-005

- EPA. 2010b. USEPA Contract Laboratory Program National Functional Guidelines for Superfund Inorganic Data Review. U.S. Environmental Protection Agency, Office of Superfund Remediation and Technology Innovation. Washington, D.C. OSWER 9240.1-51, USEPA-540-R-10-011.
- EPA. 2014. National Functional Guidelines for Superfund Organic Methods Data Review. U.S. Environmental Protection Agency, Office of Superfund Remediation and Technology Innovation. Washington, D.C. OSWER 9355.0-132, EPA-540-R-014-002.
- HDR. 2010. Aurora Corridor Improvement Project (N 185<sup>th</sup> St – N 192<sup>nd</sup> St) Contract Plans: Volume 1. TIB: 9-P-202 (004)-1. Federal Project No. CM 9999 (114).
- HDR. 2011. Aurora Corridor Improvement Project: N 185<sup>th</sup> Street to N 205<sup>th</sup> Street, Update: N 192<sup>nd</sup> Street to N 205<sup>th</sup> Street, Drainage Report. Prepared for the City of Shoreline.
- KCEL SOP #201v3. King County Environmental Laboratory Standard Operating Procedure. Field Measurement of Dissolved Oxygen. King County, WA.
- KCEL SOP #202v3. King County Environmental Laboratory Standard Operating Procedure. Field Measurement of pH. King County, WA.
- KCEL SOP #203v3. King County Environmental Laboratory Standard Operating Procedure. Field Measurement of Temperature. King County, WA.
- KCEL SOP #206v2. King County Environmental Laboratory Standard Operating Procedure. Field Measurement of Conductivity. King County, WA.
- KCEL SOP #207v1. King County Environmental Laboratory Standard Operating Procedure. Field Measurement of Turbidity using Hach 2100P. King County, WA.
- KCEL SOP #223. King County Environmental Laboratory Standard Operating Procedure. Clean Sampling of Water for Trace Metals and Organics Using Automated Samplers. King County, WA.
- KCEL SOP #234. King County Environmental Laboratory Standard Operating Procedure. Sampling Equipment Cleaning. King County, WA.
- KCEL SOP #336. King County Environmental Laboratory Standard Operating Procedure. Total Organic Carbon and Dissolved Organic Carbon Analysis in Liquids. King County, WA.
- KCEL SOP #408v3. King County Environmental Laboratory Standard Operating Procedure. *Ceriodaphnia dubia* Chronic Toxicity Test. King County, WA.

KCEL SOP #412v2. King County Environmental Laboratory Standard Operating Procedure. *Daphnia pulex* Acute Toxicity Test. King County, WA.

KCEL SOP #736v4. King County Environmental Laboratory Standard Operating Procedure. NWTPH-Dx: Analysis of Semi-Volatile Petroleum Products. King County, WA.

King County. 1998. Wastewater Treatment Division Permit-Required Confined Space Entry Program. King County Department of Natural Resources and Parks, Wastewater Treatment Division. Seattle, Washington.

King County. 2008. NPDES Stormwater Monitoring Program: Standard Operating Procedure: Continuous Measurement of Discharge. Prepared by Dean Wilson. NPDES-CM-1000.

King County. 2013. PCB/PBDE loading estimates for the Greater Lake Washington Watershed. Prepared by Curtis DeGasperi, Water and Land Resources Division. Seattle, Washington.

King County. 2014a. Echo Lake water quality: water quality monitoring results for water year 2013. Prepared for the City of Shoreline. Prepared by Lakes and Streams Monitoring Group, Water and Land Resources Division. Seattle, Washington.

King County. 2014b. Lower Duwamish Waterway Source Control: Green River Watershed Surface Water Data Report. Prepared by Carly Greyell, Debra Williston, and Deb Lester. Water and Land Resources Division. Seattle, Washington.

Hobbs, B., B. Lubliner, N. Kale, and E. Newell. 2015. Western Washington NPDES Phase I Stormwater, Permit: Final Data Characterization 2009-2013. Washington State Department of Ecology, Olympia, WA. Publication No. 15-03-001.

McIntyre, J.K., J.W. Davis, C. Hinman, K.H. Macneale, B.F. Anulacion, N.L. Scholz and J.D. Stark. 2015. Soil bioretention protects juvenile salmon and their prey from the toxic impacts of urban stormwater runoff. *Chemosphere*.  
<http://dx.doi.org/10.1016/j.chemosphere.2014.12.052>.

Shoreline (City of). Unpublished data. Echo Lake Stormwater Outfall Data, 2010-2011.

Shoreline (City of). 2005. Echo Lake Stormwater Quality Monitoring Report.

Teledyne ISCO. 1994. 4230 Flow Meter: Installation and Operation Guide. Revision HH, October 11, 2013. Part #60-3233-142 of Assembly #60-3234-051.

# Appendix A: Stormwater Treatment Installations

# Appendix A – Table of Contents

Plot DT1, Aurora Corridor Improvement Project: N 185 <sup>th</sup> St – N 192 <sup>nd</sup> St (HDR 2011)	<b>Page 1</b>
<i>This plot illustrates bioretention planter box designs used at this site. Red text has been added to describe inlet and outlet sampling. (The HDR document refers to the bioretention planter boxes as rain gardens).</i>	
Plot DT2, Aurora Corridor Improvement Project: N 185 <sup>th</sup> St – N 192 <sup>nd</sup> St (HDR 2011)	<b>Page 2</b>
<i>This plot illustrates Filterra® designs used at this site. Red text has been added to describe inlet and outlet sampling.</i>	
Plot DT5, Aurora Corridor Improvement Project: N 185 <sup>th</sup> St – N 192 <sup>nd</sup> St (HDR 2011)	<b>Page 3</b>
<i>This plot illustrates the detention tank system (DTS) design used at this site. Red text has been added to describe inlet and outlet sampling.</i>	

**GENERAL NOTES**

1. UNLESS OTHERWISE NOTED, ALL DIMENSIONS ARE IN FEET.
2. SEE SHEET PAVD4 FOR RAIN GARDEN PAY LIMITS AT CONCRETE SIDEWALK.
3. SEE SHEET DT3 FOR RAIN GARDEN OUTLET PIPE PROFILES.
4. SEE SHEET DT6 FOR PLAZA RAIN GARDEN DETAILS.
5. SEE SHEET DT7 FOR RAIN GARDEN INLET DETAILS.

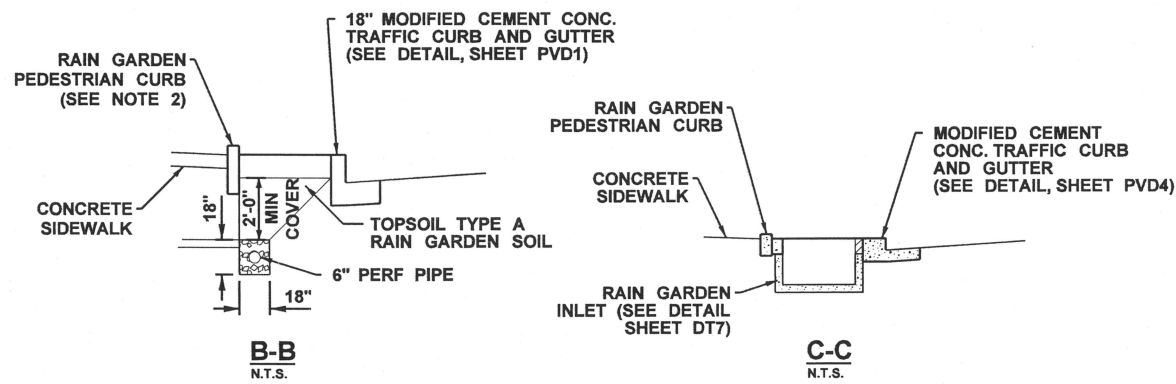
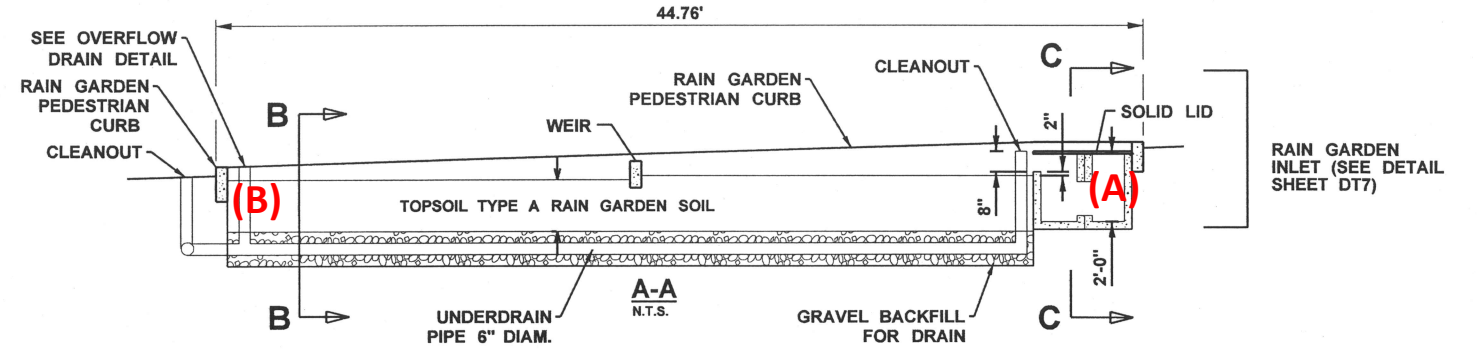
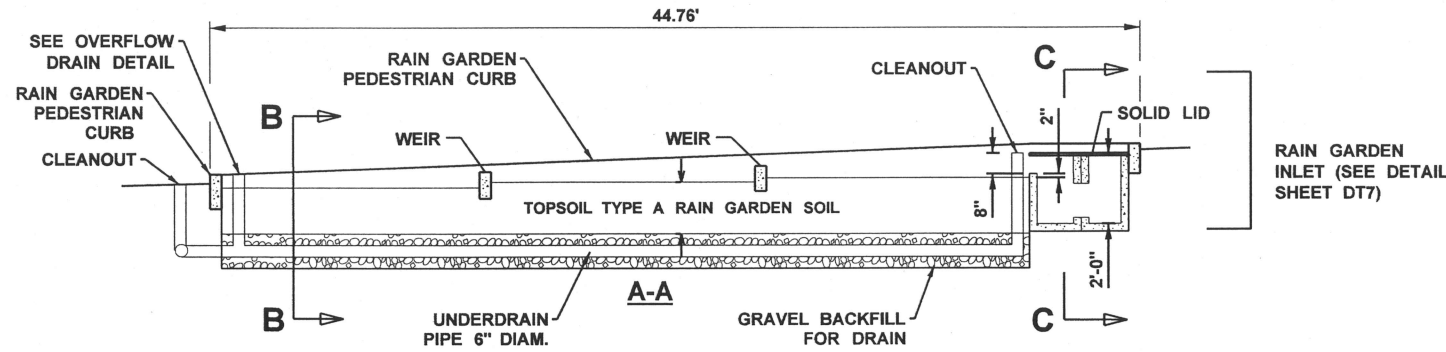
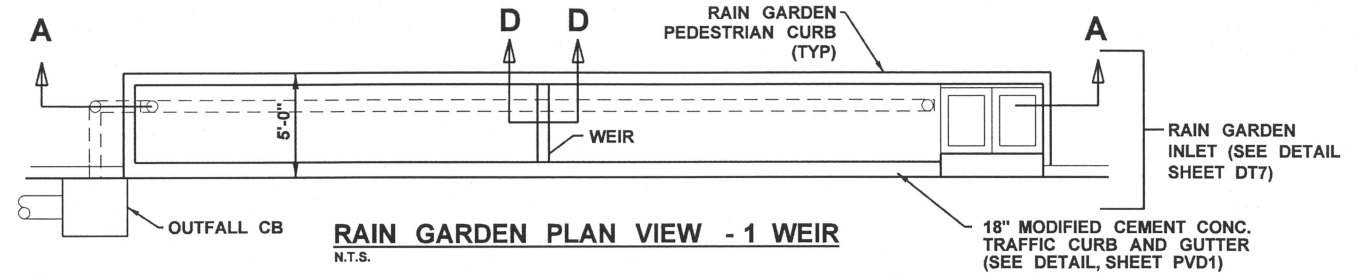
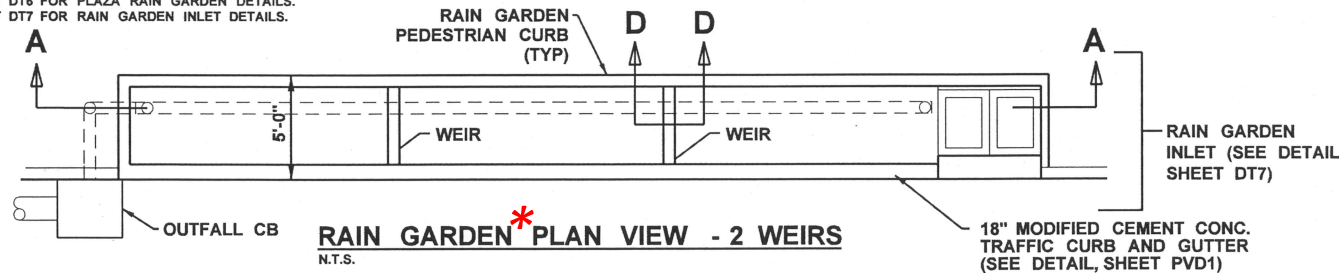

STRUCTURE NUMBER	LOCATION	NUMBER OF WEIRS
DR2-21	SH 214+63.86 (45.75' LT)	2
DR2-24	SH 215+89.42 (45.75' RT)	2
DR3-12	SH 219+47.53 (45.75' LT)	2
DR3-13	SH 220+15.75 (45.75' RT)	2
DR3-15	SH 221+01.03 (45.75' LT)	2
DR4-25	SH 222+52.27 (45.75' RT)	1

**Inlet Sampling:**  
Sampling from catch basin (A) is described in Section 6.2 of the QAPP.

**Outlet Sampling:**  
A peristaltic pump will draw effluent from the underdrain through the overflow (B).

*\*The term rain garden is used in this document, but the technical term is bioretention planter box.*

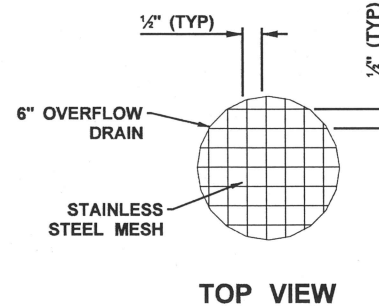
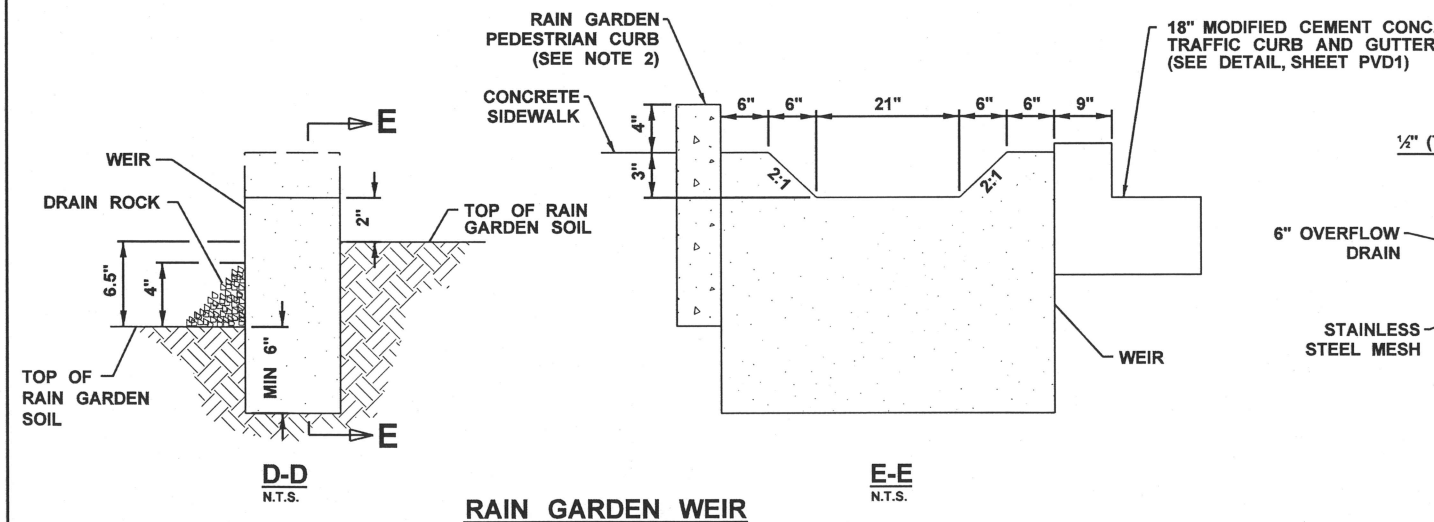

**OVERFLOW DRAIN**  
N.T.S.

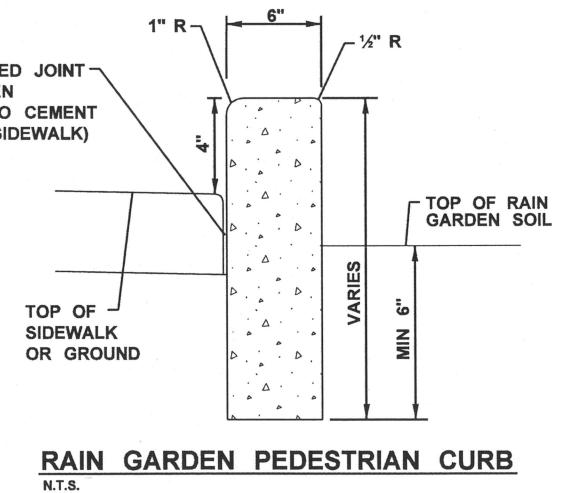
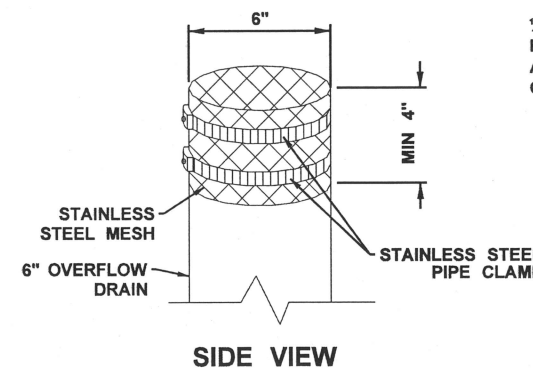

Projectwise Vault:	FILE NAME	c:\pwworking\seald03797281124463_DT1a_P3.dgn			REGION NO.	STATE	FED.AID PROJ.NO.				<b>AURORA CORRIDOR IMPROVEMENT PROJECT</b> N 185TH ST - N 192ND ST	<b>DRAINAGE DETAILS</b>	PLOT1 DT1 SHEET 104 OF 389 SHEETS
	TIME	2:20:32 PM			10	WA							
	DATE	9/10/2010			JOB NUMBER	124463							
	PLOTTED BY	cwlcox			CONTRACT NO.	CON0050153							
	DESIGNED BY	MJS			LOCATION NO.								
	ENTERED BY	BRG			DATE	9.15.10							
	CHECKED BY	LJL			BY								
PROJ. ENGR.	PAF												
REGIONAL ADM.		REVISION		DATE									



**CONSTRUCTION NOTES**

- 1) EACH UNIT SHALL BE CONSTRUCTED AT THE LOCATIONS AND ELEVATIONS ACCORDING TO THE SIZES SHOWN ON THE APPROVED DRAWINGS. ANY MODIFICATIONS TO THE ELEVATION OR LOCATION SHALL BE AT THE DIRECTION OF AND APPROVED BY THE ENGINEER.
- 2) IF THE FILTERRA IS STORED BEFORE INSTALLATION, THE TOP SLAB MUST BE PLACED ON THE BOX USING THE 2X4 WOOD PROVIDED, TO PREVENT ANY CONTAMINATION FROM THE SITE. ALL INTERNAL FITTINGS SUPPLIED (IF ANY), MUST BE LEFT IN PLACE AS PER THE DELIVERY.
- 3) THE UNIT SHALL BE PLACED ON A COMPACTED SUB-GRADE WITH A MINIMUM 6-INCH GRAVEL BASE MATCHING THE FINAL GRADE OF THE CURB LINE IN THE AREA OF THE UNIT. THE UNIT IS TO BE PLACED SUCH THAT THE UNIT AND TOP SLAB MATCH THE GRADE OF THE CURB IN THE AREA OF THE UNIT. COMPACT UNDISTURBED SUB-GRADE MATERIALS TO 95% OF MAXIMUM DENSITY AT +1 - 2% OF OPTIMUM MOISTURE. UNSUITABLE MATERIAL BELOW SUB-GRADE SHALL BE REPLACED TO THE SITE ENGINEER'S APPROVAL.
- 4) OUTLET CONNECTIONS SHALL BE ALIGNED AND SEALED TO MEET THE APPROVED DRAWINGS WITH MODIFICATIONS NECESSARY TO MEET SITE CONDITIONS AND LOCAL REGULATIONS.
- 5) ONCE THE UNIT IS SET, THE INTERNAL WOODEN FORMS AND PROTECTIVE MESH COVER MUST BE LEFT INTACT. REMOVE ONLY THE TEMPORARY WOODEN SHIPPING BLOCKS BETWEEN THE BOX AND TOP SLAB. THE TOP LID SHOULD BE SEALED ONTO THE BOX SECTION BEFORE BACKFILLING, USING A NON SHRINK GROUT, BUTYL RUBBER OR SIMILAR WATERPROOF SEAL. THE BOARDS ON TOP OF THE LID AND BOARDS SEALED IN THE UNIT'S THROAT MUST NOT BE REMOVED. THE SUPPLIER (AMERICAST OR ITS AUTHORIZED DEALER) WILL REMOVE THESE SECTIONS AT THE TIME OF ACTIVATION. BACKFILLING SHOULD BE PERFORMED IN A CAREFUL MANNER, BRINGING THE APPROPRIATE FILL MATERIAL UP IN 6" LIFTS ON ALL SIDES. PRECAST SECTIONS SHALL BE SET IN A MANNER THAT WILL RESULT IN A WATERTIGHT JOINT. IN ALL INSTANCES, INSTALLATION OF FILTERRA UNIT SHALL CONFORM TO ASTM SPECIFICATION C891 "STANDARD PRACTICE FOR INSTALLATION OF UNDERGROUND PRECAST UTILITY STRUCTURES", UNLESS DIRECTED OTHERWISE IN CONTRACT DOCUMENTS.
- 6) CURB AND GUTTER CONSTRUCTION (WHERE PRESENT) SHALL ENSURE THAT THE FLOW-LINE OF THE FILTERRA UNITS IS AT A GREATER ELEVATION THAN THE FLOW-LINE OF THE BYPASS STRUCTURE OR RELIEF (DROP INLET, CURB CUT OR SIMILAR). FAILURE TO COMPLY WITH THIS GUIDELINE MAY CAUSE FAILURE AND/OR DAMAGE TO THE FILTERRA ENVIRONMENTAL DEVICE.
- 7) EACH FILTERRA UNIT MUST RECEIVE ADEQUATE IRRIGATION TO ENSURE SURVIVAL OF THE LIVING SYSTEM DURING PERIODS OF DRIER WEATHER. THIS MAY BE ACHIEVED THROUGH A PIPED SYSTEM, GUTTER FLOW OR THROUGH THE TREE GRATE.
- 8) EACH FILTERRA UNIT SHALL USE THE UA CHINOOK ORNAMENTAL GRATE.

**ACTIVATION**

- 1) ACTIVATION OF THE FILTERRA UNIT IS PERFORMED ONLY BY THE SUPPLIER. PURCHASER IS RESPONSIBLE FOR FILTERRA INLET PROTECTION AND SUBSEQUENT CLEAN OUT COST. THIS PROCESS CANNOT COMMENCE UNTIL THE PROJECT SITE IS FULLY STABILIZED AND CLEANED (FULL LANDSCAPING, GRASS COVER, FINAL PAVING AND STREET SWEEPING COMPLETE), NEGATING THE CHANCE OF CONSTRUCTION MATERIALS CONTAMINATING THE FILTERRA SYSTEM. CARE SHALL BE TAKEN DURING CONSTRUCTION NOT TO DAMAGE THE PROTECTIVE THROAT AND TOP PLATES.
- 2) ACTIVATION INCLUDES INSTALLATION OF PLANT(S) AND MULCH LAYERS AS NECESSARY.

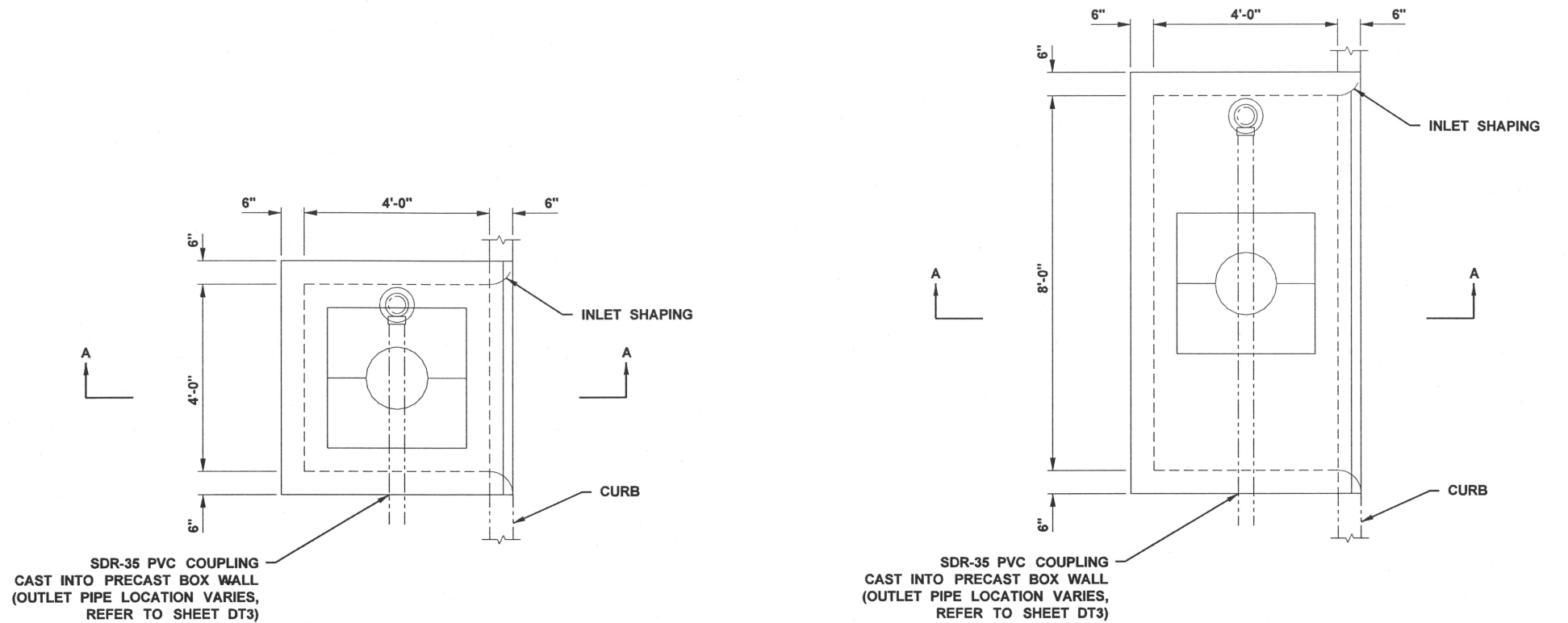

**PLAN VIEW - 4'x4' FILTERRA**  
N.T.S.

**PLAN VIEW - 4'x8' FILTERRA**  
N.T.S.

**Outlet Sampling:**  
A peristaltic pump will draw water from the underdrain (A) through the cleanout (B)

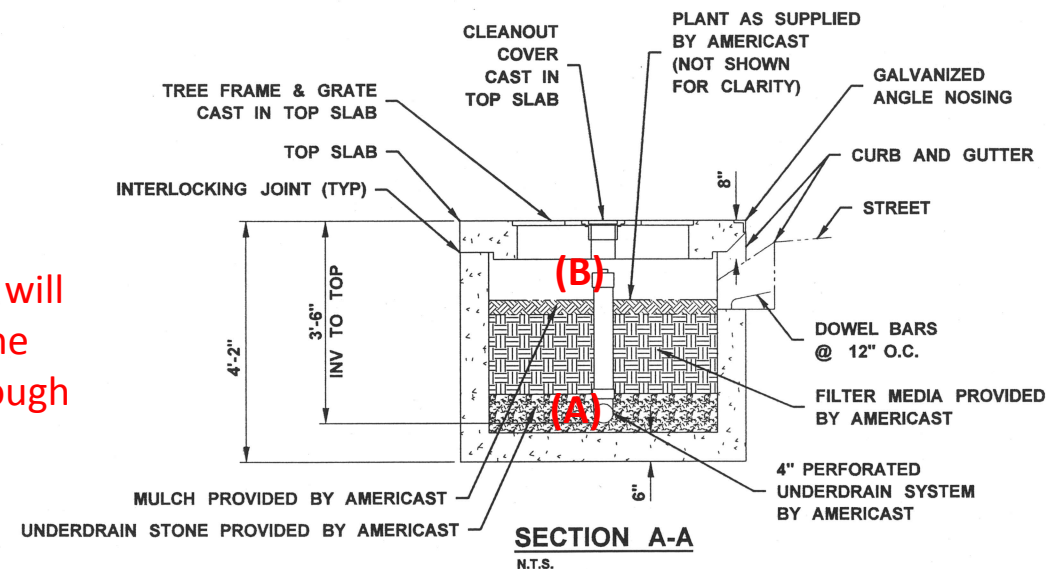

**PRECAST FILTERRA® UNIT**  
**NARROW WIDTH CONFIGURATION**

**FILTERRA DETAIL**

**Inlet Sampling:**  
A partial physical barrier will be placed along the curb opening to concentrate the flow and allow a peristaltic pump to draw water from the surface. The exact design is yet to be determined. Please see Section 6.2 of the QAPP for more details.

ProjectWise Vault: DR

FILE NAME	c:\pwworking\seald0379728\124463_DT2a_P3.dgn	REGION NO.	STATE	FED.AID PROJ.NO.				AURORA CORRIDOR IMPROVEMENT PROJECT N 185TH ST - N 192ND ST	PLOT2
TIME	1:13:12 PM	10	WA						DT2
DATE	9/2/2010	JOB NUMBER			9.15.10 DATE P.E. STAMP BOX	CITY OF SHORELINE	HDR ENGINEERING INC.	DRAINAGE DETAILS	SHEET
PLOTTED BY	cwilcox	124463							105
DESIGNED BY	MJS	CONTRACT NO.							OF
ENTERED BY	BRG	CON0050153							389
CHECKED BY	LJL	LOCATION NO.							SHEETS
PROJ. ENGR.	PAF								
REGIONAL ADM.		REVISION	DATE	BY					



**GENERAL NOTES**

1. UNLESS OTHERWISE NOTED, ALL DIMENSIONS ARE IN FEET.
2. SEE SHEETS UDD9 - UDD11 FOR PLAZA DETAILS.
3. SEE SHEET DT6 FOR PLAZA RAINGARDEN DETAILS.
4. SEE SHEET DT7 FOR CMP DETENTION SYSTEM MANHOLE CAP DETAIL.

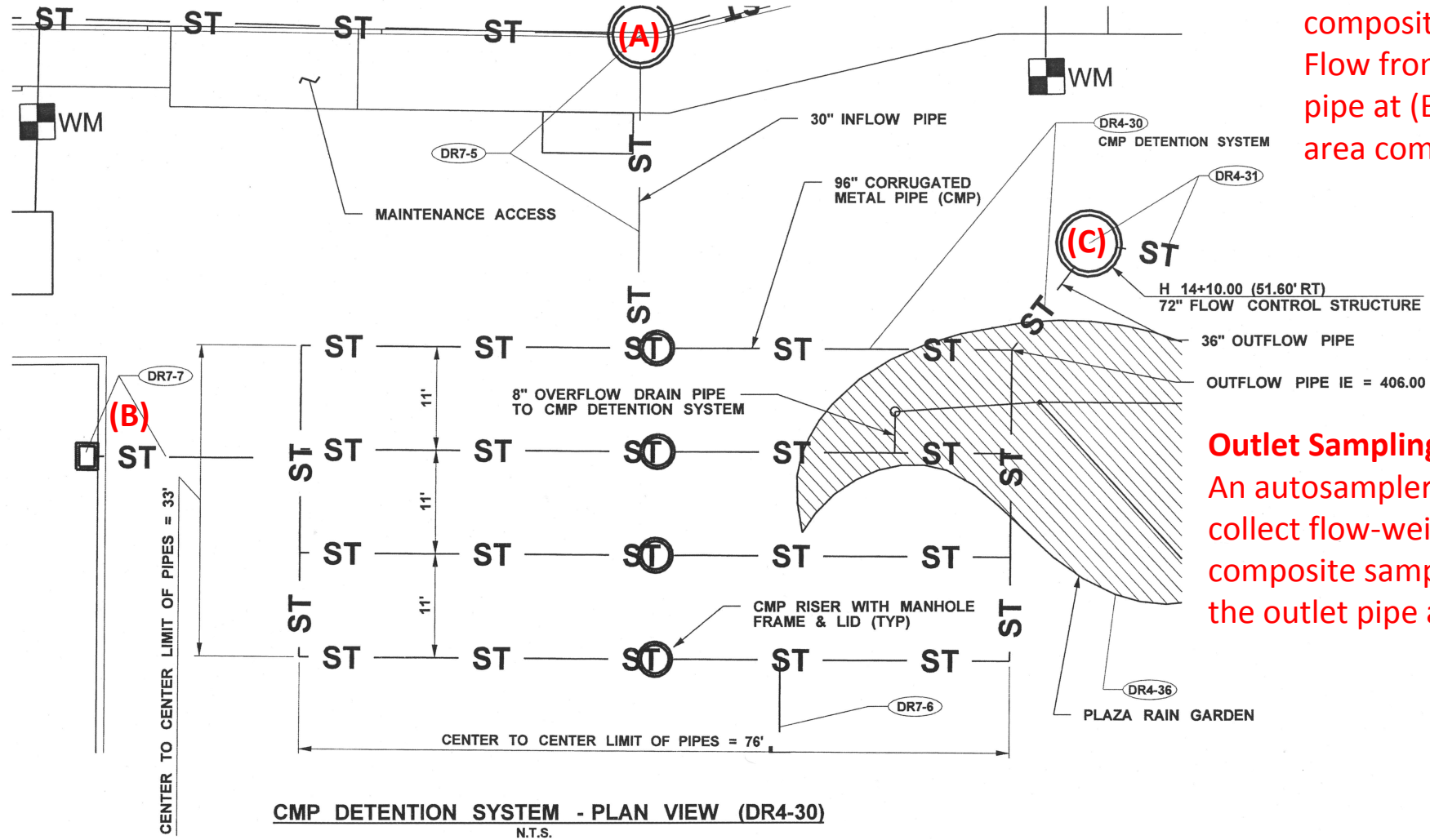

**Inlet Sampling:**

An autosampler will collect flow-weighted composite samples from the inlet pipe at (A). Flow from subbasin 2 enters from the inlet pipe at (B); this represents a minor drainage area compared to the inlet at (A).

**Outlet Sampling:**

An autosampler will collect flow-weighted composite samples from the outlet pipe at (C).

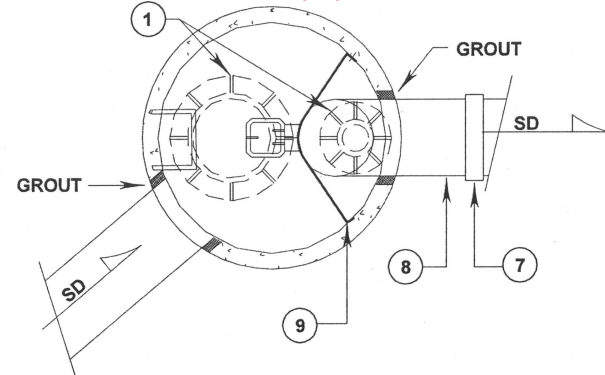

**NOTES:**

1. INSTALL 1-18" AND 1-24" DIA. MH. ACCESS PER STND DWG 716, ONE SO THAT THE LIFT GATE IS VISIBLE AND THE STEPS ARE CLEAR AND DIRECTLY ACCESSIBLE. THE OTHER IS OVER THE RESTRICTOR UNIT.
2. OVERFLOW ELEVATION = 412.00
3. RESTRICTOR UNIT - SEE SHORELINE STD. PLAN 761.
4. POLYPROPYLENE PLASTIC STEP
5. MIN CLEARANCE = 36"
6. 72" TYPE 2 CB
7. BAND STRAP WITH GASKET
8. SEE PLAN AND SPECIFICATIONS FOR SIZE AND TYPE OF PIPE ENTERING AND EXITING CB.
9. SECURE RESTRICTOR TO CB WITH 8 GA ALUMINUM STRAPS BOLT TO CB WALL WITH STAINLESS STEEL ANCHOR BOLTS. ONE STRAP ABOVE AND BELOW OUTLET REQUIRED, INTERMEDIATE STRAPS REQUIRED FOR RESTRICTOR RISERS GREATER THAN 12' ABOVE OUTLET.
10. LIFT HANDLE CONNECTOR - SEE SHORELINE STD. PLAN 762.
11. INVERT ELEVATION = 406.00
12. SHEAR GATE - SEE SHORELINE STD. PLAN 762.
14. I.D. PLATE PER K.C.S.W.D.M. CORE REQ. #1.2.6

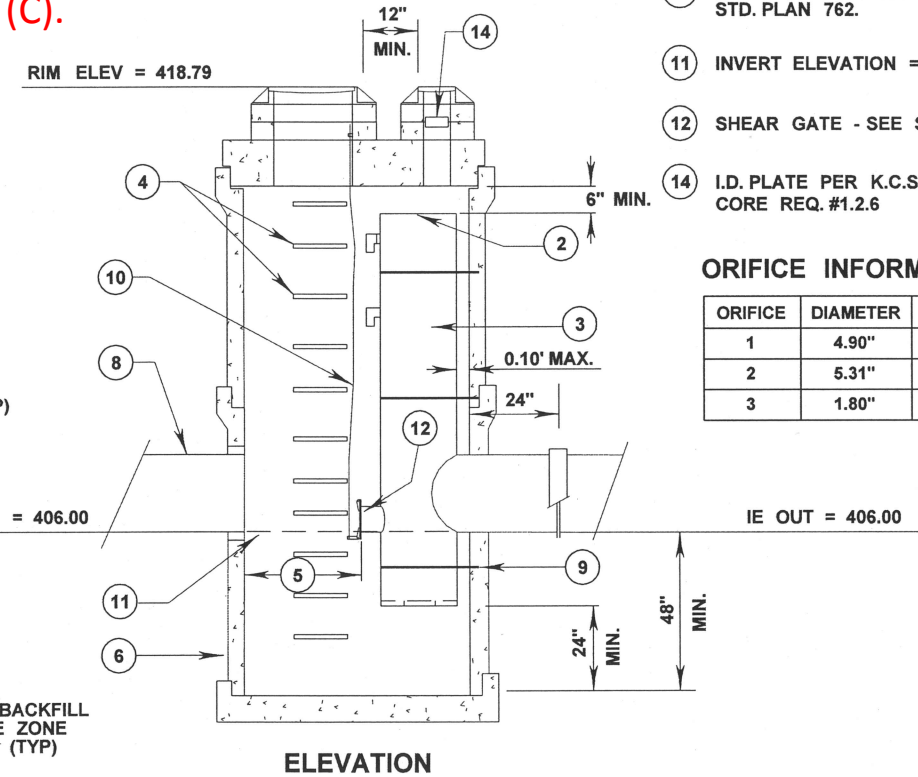

**ORIFICE INFORMATION**

ORIFICE	DIAMETER	HEIGHT	ELEVATION
1	4.90"	0.000 ft	404.00
2	5.31"	4.002 ft	408.00
3	1.80"	4.500 ft	408.50

**FLOW CONTROL STRUCTURE DETAILS (DR4-31)**  
N.T.S.

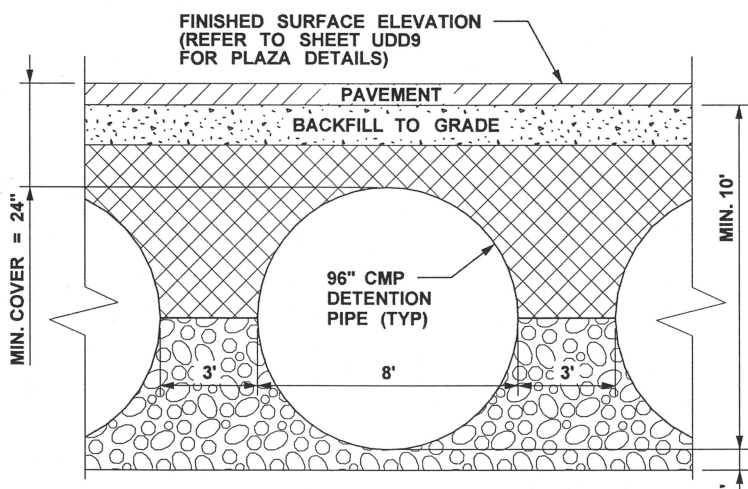

**CMP DETENTION SYSTEM - TYPICAL SECTION VIEW**  
N.T.S.

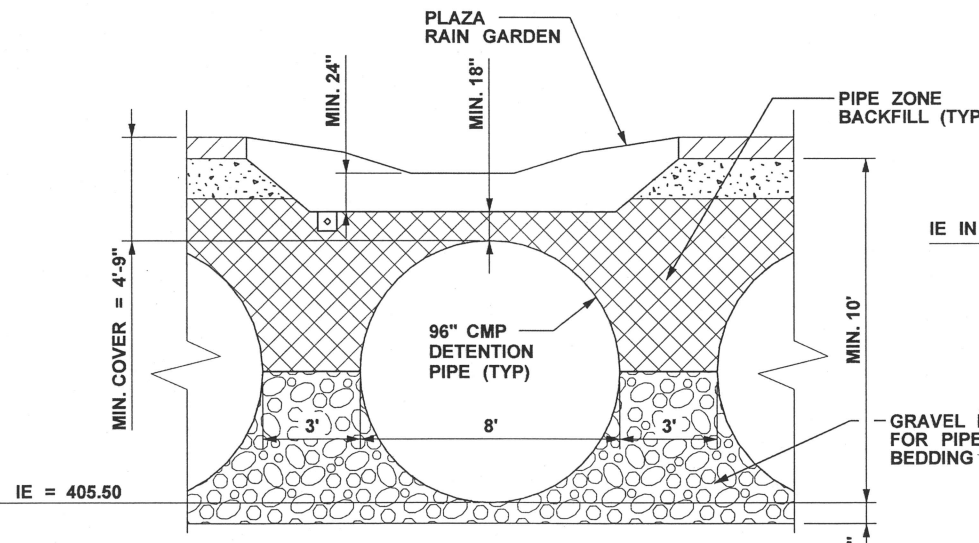

**CMP DETENTION SYSTEM - SECTION VIEW AT RAIN GARDEN**  
N.T.S.

ProjectWise Vault: DR

FILE NAME	c:\pwworking\seald0379728\124463_DT5a_P3.dgn	REGION NO.	10	STATE	WA	FED.AID PROJ.NO.					<b>AURORA CORRIDOR IMPROVEMENT PROJECT</b> N 185TH ST - N 192ND ST	<b>PLOTS</b>  DT5	
TIME	4:52:04 PM	JOB NUMBER	124463	CONTRACT NO.	CON0050153	LOCATION NO.							SHEET 108 OF 389 SHEETS
DATE	9/14/2010	DESIGNED BY	BRG	CHECKED BY	LJL	PROJ. ENGR.	PAF	DATE					
PLOTTED BY	cwilcox	ENTERED BY	BRG	PROJ. ENGR.	PAF	REGIONAL ADM.		REVISION		DATE		BY	

# **Appendix B: Chain of Custody Form**

Project: 421879-240

**CHAIN OF CUSTODY**

<i>Relinquished by</i>	<i>Date</i>	<i>Time</i>
<i>Received by</i>	<i>Date</i>	<i>Time</i>
<i>Sample Numbers</i>		<i>[All]</i>

Sample Number	T_FW_SW_EFF-1	T_FW_SW_EFF-2	T_FW_SW_EFF-3
QC Link			
Locator	FW-EBI	FW-EBO	FW-WBI
Short Loc Desc	EBI	EBO	WBI
Locator Desc	EAST BIORETENTION FACILITY INLET	EAST BIORETENTION FACILITY OUTLET	WEST BIORETENTION FACILITY INLET
Site	KING COUNTY	KING COUNTY	KING COUNTY
Comments			
Start Date/Time			
End Date/Time			
Time Span			
Sample Depth			
Dept, Matrix, Prod	3 LG ALK 3 LG DOC 3 LG NH3 3 LG NO23 3 LG ORTHOP 3 LG TOC 3 LG TOTN 3 LG TOTP 3 LG TSS 6 LG CA-ICPMS 6 LG ICPMS-HARDNESS 6 LG MG-ICPMS 7 LG PAH-SIM 10 LG EPA1668PCB	3 LG ALK 3 LG DOC 3 LG NH3 3 LG NO23 3 LG ORTHOP 3 LG TOC 3 LG TOTN 3 LG TOTP 3 LG TSS 6 LG CA-ICPMS 6 LG ICPMS-HARDNESS 6 LG MG-ICPMS 7 LG PAH-SIM 10 LG EPA1668PCB	3 LG ALK 3 LG DOC 3 LG NH3 3 LG NO23 3 LG ORTHOP 3 LG TOC 3 LG TOTN 3 LG TOTP 3 LG TSS 6 LG CA-ICPMS 6 LG ICPMS-HARDNESS 6 LG MG-ICPMS 7 LG PAH-SIM 10 LG EPA1668PCB